

**United States Department of the Interior
National Park Service**

**National Register of Historic Places
Registration Form**

1. Name of Property

historic name Kreienkamp Store

other names/site number N/A

2. Location

street & number 19160 Melrose Road [N/A] not for publication

city or town Wildwood [N/A]vicinity

state Missouri code MO county St. Louis code 189 zip code 63038

3. State/Federal Agency Certification

As the designated authority under the National Historic Preservation Act, as amended, I hereby certify that this nomination request for determination of eligibility meets the documentation standards for registering properties in the National Register of Historic Places and meets the procedural and professional requirements set forth in 36 CFR Part 60. In my opinion, the property meets does not meet the National Register criteria. I recommend that this property be considered significant nationally statewide locally.
(See continuation sheet for additional comments [].)

Signature of certifying official/Title  Claire F. Blackwell/Deputy SHPO

Date 30 March 2010

Missouri Department of Natural Resources
State or Federal agency and bureau

In my opinion, the property meets does not meet the National Register criteria.
(See continuation sheet for additional comments [].)

Signature of certifying official/Title

State or Federal agency and bureau

4. National Park Service Certification

I hereby certify that the property is:

entered in the National Register
See continuation sheet [].

determined eligible for the
National Register
See continuation sheet [].

determined not eligible for the
National Register.

removed from the
National Register

other, explain
See continuation sheet [].

Signature of the Keeper

Date

5. Classification

Ownership of Property	Category of Property	Number of Resources within Property	
		Contributing	Noncontributing
<input checked="" type="checkbox"/> private	<input checked="" type="checkbox"/> building(s)		
<input type="checkbox"/> public-local	<input type="checkbox"/> district	<u>1</u>	<u>0</u> buildings
<input type="checkbox"/> public-State	<input type="checkbox"/> site	<u>0</u>	<u>0</u> sites
<input type="checkbox"/> public-Federal	<input type="checkbox"/> structure	<u>0</u>	<u>0</u> structures
	<input type="checkbox"/> object	<u>0</u>	<u>0</u> objects
		<u>1</u>	<u>0</u> Total

Name of related multiple property listing.
N/A

Number of contributing resources previously listed in the National Register.
0

6. Function or Use

Historic Function
COMMERCE/TRADE: department store
SOCIAL: meeting hall
GOVERNMENT: post office
OTHER: stage coach stop
DOMESTIC: single dwelling

Current Functions
DOMESTIC: single dwelling

7. Description

Architectural Classification
Greek Revival
Other: General store

Materials
foundation Stone
walls Wood
roof Asphalt
other

Narrative Description

(Describe the historic and current condition of the property on one or more continuation sheets.)

8. Statement of Significance

Applicable National Register Criteria

A Property is associated with events that have made a significant contribution to the broad patterns of our history

B Property is associated with the lives of persons significant in our past.

C Property embodies the distinctive characteristics of a type, period, or method of construction or represents the work of a master, or possesses high artistic values, or represents a significant and distinguishable entity whose components lack individual distinction.

D Property has yielded, or is likely to yield, information important in prehistory or history.

Criteria Considerations

Property is:

A owned by a religious institution or used for religious purposes.

B removed from its original location.

C a birthplace or grave.

D a cemetery.

E a reconstructed building, object, or structure.

F a commemorative property.

G less than 50 years of age or achieved significance within the past 50 years.

Narrative Statement of Significance

(Explain the significance of the property on one or more continuation sheets.)

9. Major Bibliographic References

Bibliography

(Cite the books, articles and other sources used in preparing this form on one or more continuation sheets.)

Previous documentation on file (NPS):

preliminary determination of individual listing (36 CFR 67) has been requested

previously listed in the National Register

previously determined eligible by the National Register

designated a National Historic Landmark

recorded by Historic American Buildings Survey

recorded by Historic American Engineering Record

Areas of Significance

COMMERCE

ARCHITECTURE

Periods of Significance

1860-1950

Significant Dates

N/A

Significant Person(s)

N/A

Cultural Affiliation

N/A

Architect/Builder

UNKNOWN

Primary location of additional data:

State Historic Preservation Office

Other State Agency

Federal Agency

Local Government

University

Other:

Name of repository: St. Louis Co. Dept. of Parks and Recreation

10. Geographical Data

Acreage of Property less than one acre

UTM References

A. Zone	Easting	Northing	B. Zone	Easting	Northing
15	698560	4271540			

C. Zone	Easting	Northing	D. Zone	Easting	Northing
---------	---------	----------	---------	---------	----------

[] See continuation sheet

Verbal Boundary Description

(Describe the boundaries of the property on a continuation sheet.)

Boundary Justification

(Explain why the boundaries were selected on a continuation sheet.)

11. Form Prepared By

name/title see continuation sheet

organization _____ date _____

street & number _____ telephone _____

city or town _____ state _____ zip code _____

Additional Documentation

Submit the following items with the completed form:

Continuation Sheets

Maps

A **USGS map** (7.5 or 15 minute series) indicating the property's location.

A **Sketch map** for historic districts and properties having large acreage or numerous resources.

Photographs

Representative **black and white photographs** of the property.

Additional Items

(Check with the SHPO or FPO for any additional items)

Property Owner

(Complete this item at the request of SHPO or FPO.)

name James F. and G. Lynne Martin

street & number 19160 Melrose Road telephone 636/458-3306

city or town Wildwood state Missouri zip code 63038

United States Department of the Interior
National Park Service

National Register of Historic Places
Continuation Sheet

Section 7 Page 1

Kreienkamp Store
St. Louis County, Missouri

Summary: The Kreienkamp Store, 19160 Melrose Road, Wildwood, Missouri is a frame, two-story, T-shaped, cross-gabled building. Stylistically, the building mainly displays modest Greek Revival influences. Built in circa 1860, the original front gabled portion was expanded to its present configuration with the addition of a frame two-story residential wing between 1897 and 1915. The symmetrical main block features a two-story porch with delicate turned supports flanked, on the first floor, by display windows with panel aprons. The five-bay wing is the same height as the store portion and its gable end has similar cornice returns. In the rear, a two-story porch with truncated corners and turned supports serves both the wing and main block. Because the entire building is in excellent condition and closely resembles its circa 1915 (or earlier) appearance as indicated by historic photographs, integrity of location, design, setting, materials, workmanship, feeling and association is retained.

Elaboration: The Kreienkamp Store faces northeast from its hilltop location three miles south of the Missouri River and 33 miles west of St. Louis, in west St. Louis County. The area is predominantly rural and the terrain is scenic, with wooded hills. The land is flat along Melrose Road but slopes significantly behind the building. The 20' x 36' main block sits adjacent to the site of a circa 1855-56 one-story log building, long removed, which also served the Melrose area as an early general store and post office. The circa 1860 main block rests on log joists with hewn tops and a stone foundation. Historic photographs indicate that the original log store, to which a half-story was added in 1880, was adjacent to the west side of the main block but a few feet farther north than the present 22' x 44' wing. This wing was constructed between circa 1897 and 1915. Several feet west of the wing's gable end is the ruin of a concrete ice house and, just beyond the south boundary, a transverse frame barn, a chicken house, a smokehouse/wash house, and a cistern with a pump. While these properties date from the turn of the century, they did not contribute significantly to the operation of the store and consequently are not included.

The main block (the store portion) shows a modest Greek Revival influence. Greek Revival is suggested by the front-gabled form with cornice returns, and by pedimented door and window openings. The ridge of the residential wing is the same height as the ridge of the main block. The wing extends westward parallel to Melrose Road and its gable end has cornice returns similar to those in the main block. The two balloon-frame sections are sheathed in their original white-painted wood siding. Full-length oak corner posts (4" x 6") are doweled to pine braces let in to full-length and in some cases mortised studs. A three-foot vertical board fence, painted white, located between the road and the Kreienkamp Store, is a recent addition.

In the primary (north) façade, a 3/3 window which slides horizontally is centered in the gable of the main block. On the first floor, large display windows with paneled aprons flank the double-leaf entrance. Photos indicate that these fixed windows replaced original double-hung 6/6 units with shutters sometime between 1897 and 1915, the timeframe during which the present wing was constructed. More than anything else, since signage apparently was minimal or nonexistent, the display windows announced that

United States Department of the Interior
National Park Service

National Register of Historic Places
Continuation Sheet

Section 7 Page 2

Kreienkamp Store
St. Louis County, Missouri

the building was a store as well as a residence. Double screen doors lie flush with the storefront wall and lead to inset double storm doors. Original transom doors were replaced with full-height doors, apparently in the 1890s. The original doors are intact in a barn on the property, along with some original wood shutters.

The two-story porch extends across the central third of the storefront. Four turned posts provide support at each level. The floor is concrete, a circa 1915 or earlier replacement of the original wood deck. Pivoting, two-piece, square metal bases support the lower posts. A hipped, asphalt-shingled porch roof is attached just below the gable window. The balcony is enclosed by an ornate scrollwork balustrade and can be accessed from the second story by a single door. Historic photographs indicate that the porch roof and turned posts were added between 1890 and 1897. Original porch supports (at the same location as the present posts) apparently were square with chamfered edges. The storefront's symmetrical design is completed by double-hung 6/6 windows flanking the balcony. A removable privacy balustrade is currently in place on the first floor porch to prevent public access to the front doors.

A seven foot section of the store's west wall extends from the storefront to the residential addition. A 6/6 window with a pedimented head is at the second floor level near the juncture of the two sections. A first floor window was located directly below the existing window, but was removed and siding pieced in over the opening sometime after 1915.

The east wall of the store retains its original fenestration consisting of one 6/6 window on the first floor and two 6/6 windows on the second, all pedimented. The first floor window had been concealed for several years by a small nonhistoric addition over stone steps to the basement. The addition was removed in 1996 and the window was rebuilt to its original appearance. The cellar bulkhead was reconstructed and covered with a hinged wooden door as depicted in an 1897 photograph.

The south (rear) façade of the building is equipped with a two-story porch with beveled or truncated corners. The porch extends across the western half of the store's south wall and continues across the eastern quarter of the wing. Rebuilt in 1993, this porch has turned supports similar to those on the main porch. The original rear porch was one-story, apparently, and was badly deteriorated. The historic turned posts were used on the first floor of the present porch, and the current design also incorporates the beveled-corner plan of the original porch. Wooden steps provide the only access to the second floor of the porch. While the addition of an upstairs floor to the rear porch may not be authentic (there are no historic views of the south elevation), it is an appropriate type and design and this façade is not easily viewed because of the terrain.

A single-leaf entrance is centered in the south wall of the store portion. A double-hung 6/6 window is east of the doorway. Upstairs, two double-hung 6/6 windows are on the second story and a louvered window is in the gable.

United States Department of the Interior
National Park Service

National Register of Historic Places
Continuation Sheet

Section 7 Page 3

Kreienkamp Store
St. Louis County, Missouri

The south end of the main block extends approximately seven feet beyond the south wall of the residential addition.

The 22' x 44' residential wing is centered on the west wall of the store. On the front (north) façade of the wing, concrete steps lead to transomed single-leaf entrances at the east and west ends. The two-light transoms and an oval window in the easternmost entrance door are the most elaborate features of this façade. Three double-hung 2/2 windows with flat heads are evenly spaced between the two exterior doors on the first story. On the second story, four double-hung 2/2 windows are aligned above the easternmost door and each of the three windows.

The rear (south) elevation of the wing retains most of its original fenestration including two transomed single-leaf entrances immediately west of the main block. West of the entrances are three double-hung 2/2 windows and a small double-hung 1/1 window. Four double-hung 2/2 windows on the second floor are directly opposite similar windows in the north wall. Except for the second upstairs window from the west, the second floor windows are also aligned above a first floor door or window opening. The small first floor window is probably nonoriginal. The south elevation of the wing includes the western half of the back porch.

On the west façade of the wing, the quarried rock foundation is exposed about four feet above grade where the ground slopes downhill. Upstairs, the façade is pierced by two evenly spaced double-hung 2/2 windows. The plain boxed cornice wraps into the gable. A wooden hatch door in the foundation provides access to the addition's crawlspace.

The original shake roof was replaced long ago with a metal roof over the store portion and asphalt shingles over the residential addition. A new "architectural shake" asphalt shingle roof was installed over the entire structure in 1994. The original heat source for the store portion appears to have been a wood or coal stove. Two chimneys added since circa 1915 have been removed.

The store interior, which consists of one large room on the first floor, retains many original features. The nine foot ceilings are covered with decorative pressed metal. Plaster in the upper two-thirds of the walls has been replaced with drywall. The lower portion of the walls consists of tongue-and-groove wainscoting. Six original "schoolhouse" style enclosed-globe light fixtures with drawn metal bases still hang from the ceiling. Worn flooring has been replaced in several patches over the past century. Throughout the building, original doors are either four-panel units or are hand-framed from tongue-and-groove boards with cross-bracing. At some point, a stairway to the family living quarters on the second floor was removed from the southwest corner. The outline of where the stairway was attached to the tongue-and-groove boards is still plainly visible. Floor plans (Figures 1 and 2) indicate original as well as current uses of the interior space.

United States Department of the Interior
National Park Service

National Register of Historic Places
Continuation Sheet

Section 7 Page 4

Kreienkamp Store
St. Louis County, Missouri

Closely arranged original shelves still line the east wall and half of the west wall, complete with metal trim to hold preprinted price tags. A metal-lined storage closet has been converted into a display cabinet. The store's 20-foot sales counter, paneled like the aprons below the front display windows, has been shortened and moved into the addition where it serves as a kitchen island.

Upstairs above the store, the interior walls of tongue-and-groove boards are protected by chair rail moldings. Windows and doorways on the second floor have heavier built-up trim that provided a natural stop for the plastered walls. Walls in the south upstairs room have been wood-grained with mustard paint. The second floor contains a bedroom, storage areas and a study. A stairway at the south end of the second floor leads to a 10' x 36' bedroom/children's room in the attic.

In the residential wing, the first floor has a nine-foot ceiling while the second floor which served as a meeting hall has a vaulted 10-foot ceiling. Walls and ceilings are covered with beaded pine tongue-and-groove boards and the flooring is hardwood. Door and window enframements in the wing have a grooved architrave pattern with bullseye corner blocks. A hall stairway along the east wall provides access to both the living quarters over the store and the former meeting hall. A second stairway on the west end of the addition provided direct access to the meeting hall. The first floor space is divided into kitchen, bedroom, storage and bath areas. The hallway is accessed from front and rear entrances. The westernmost front entrance opens onto the west stairway. A second back entrance leads to the kitchen.

Since 1918, the second floor of the wing has been divided into three large rooms currently used as a parlor and two bedrooms, plus a bathroom.

The basement has a nine-foot ceiling and a dirt floor. Its dry-stacked stone walls are approximately two feet thick. The walls have been plastered to reduce the infiltration of ground water. Each of the one-foot diameter log joists that support the store is approximately 20 feet long. Between the joists, an insulation layer of straw and mud rests on a bed of oak split-shake supports that are attached to the log joists (see Figure 3).

Nearby are a transverse frame barn, a poultry house, a smokehouse/wash house, the ruin of a collapsed concrete ice house, and a cistern with a pump. The ice house ruin is northwest of the Kreienkamp Store, while the barn and poultry house are south. The barn and poultry house are gable-roofed buildings sided with vertical boards.

United States Department of the Interior
National Park Service

National Register of Historic Places
Continuation Sheet

Section 7 Page 5

Kreienkamp Store
St. Louis County, Missouri

Figure 1: First Floor Plan

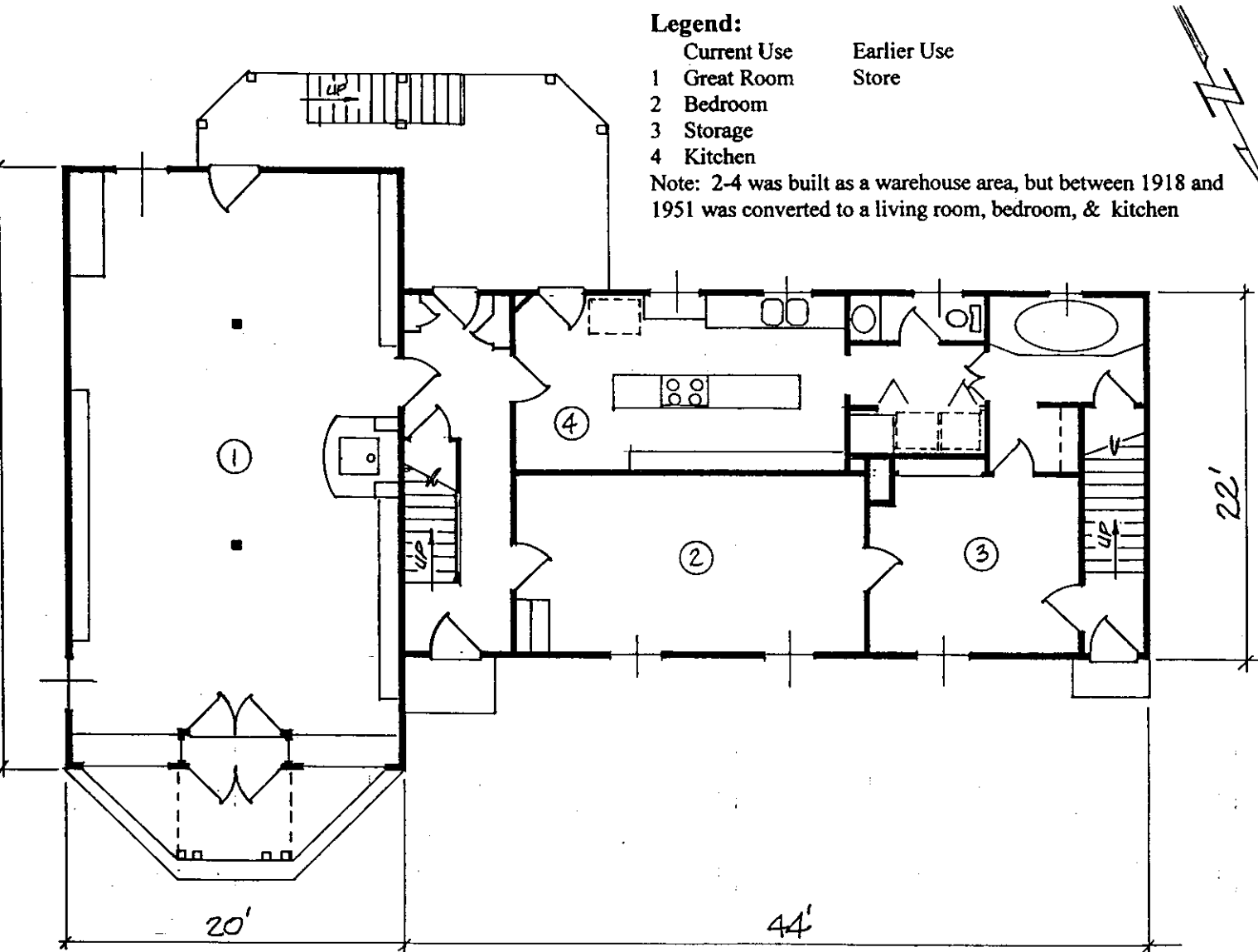

Kreienkamp Store
First Floor Plan
Scale: 1/8" = 1'-0"

United States Department of the Interior
National Park Service

National Register of Historic Places
Continuation Sheet

Section 7 Page 6

Kreienkamp Store
St. Louis County, Missouri

Figure 2: Second Floor Plan

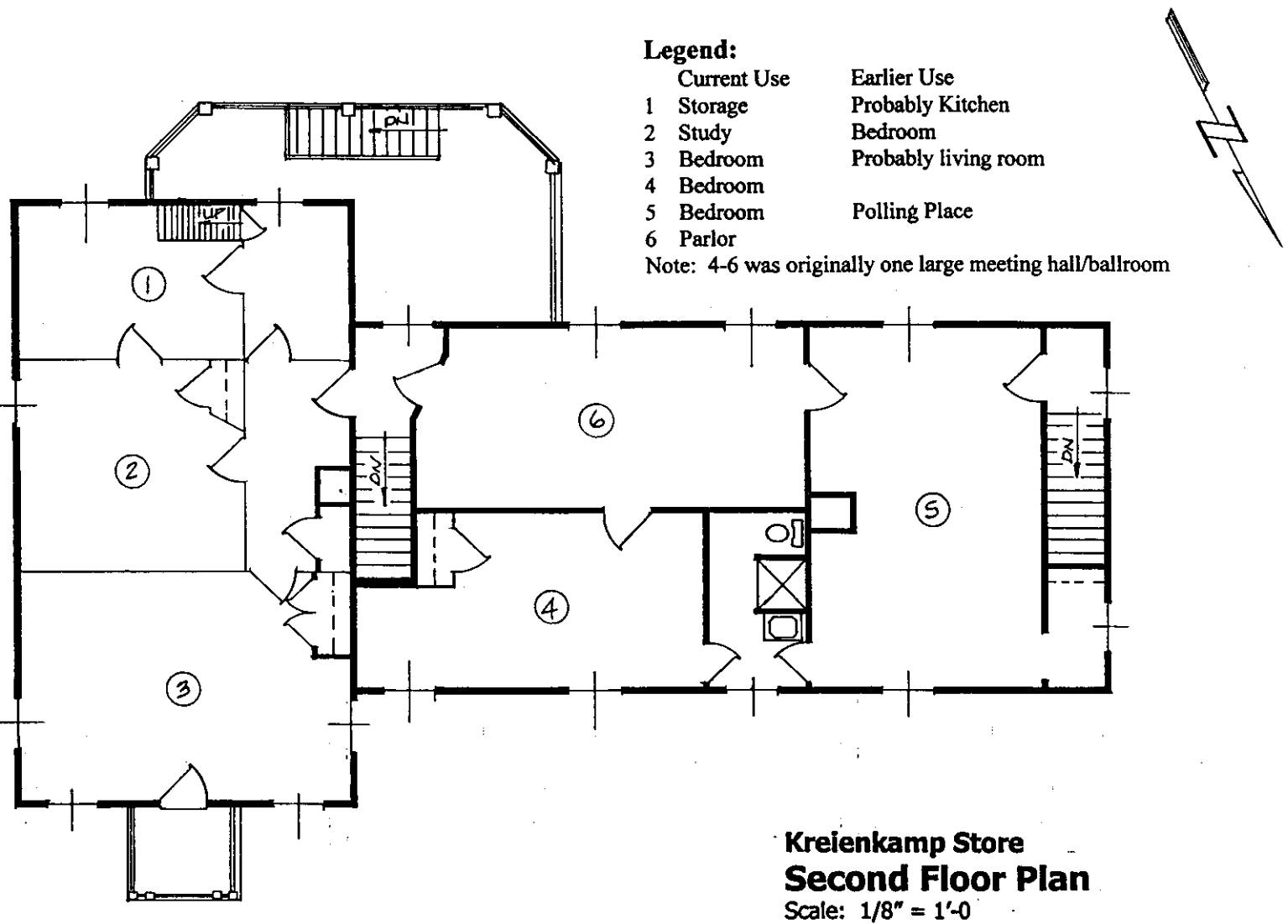

United States Department of the Interior
National Park Service

National Register of Historic Places
Continuation Sheet

Section 7 Page 7

Kreienkamp Store
St. Louis County, Missouri

Figure 3: Store Floor Section

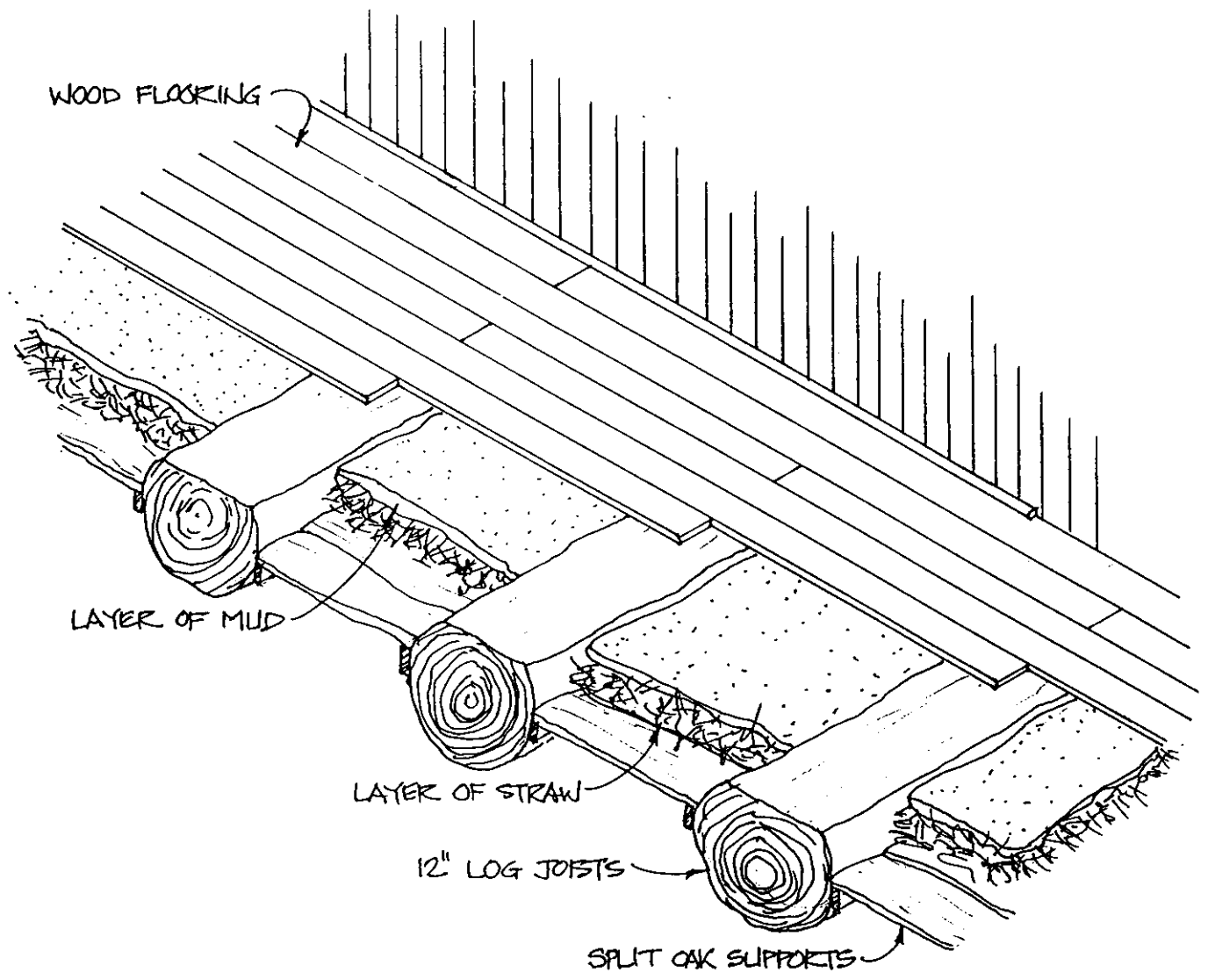

SECTION THROUGH STORE FLOOR
(NO SCALE)

United States Department of the Interior
National Park Service

National Register of Historic Places
Continuation Sheet

Section 8 Page 8

Kreienkamp Store
St. Louis County, Missouri

Summary: The Kreienkamp Store, 19160 Melrose Road, Wildwood, Missouri, is eligible for listing in the National Register of Historic Places under Criteria A and C, with significance in the areas of Commerce and Architecture. Like many country stores, the Kreienkamp Store influenced local settlement and contributed to the development of an emerging rural community, in this case Melrose. In various forms, the Kreienkamp Store was central to the trading of goods and commodities in western St. Louis County from circa 1860 until 1978, and for many years served as a post office and stagecoach stop. Actually, the Kreienkamp Store was a continuation of an even older general store and post office constructed of logs on an adjacent site in 1855-56. Architecturally, the Kreienkamp Store is a well-preserved representative of a 19th century Southern country store as described by Lewis E. Atherton.¹ The Kreienkamp Store follows Atherton's typology in that it evolved over time to fit the needs of the owners and changes in marketing/display methods. The present form of the store and its addition was achieved at some point between 1897 and 1915. The store is also a good local example of a vernacular building with modest Greek Revival influences as suggested by the front-gabled form of the main block with its pedimented door and window openings. Finally, the Kreienkamp Store is the best and least altered vintage general store in St. Louis County, as determined by historic architectural surveys conducted by the St. Louis County Department of Parks and Recreation in 1988-89.² The period of significance, 1860 through 1950, begins with the first use of the main block portion as a general store and ends with the arbitrary 50-year cutoff date for National Register properties.

Elaboration/The Development of Melrose: The Kreienkamp Store was built to serve central Melrose, a development platted and recorded in 1852 by Charles H. Haven, a St. Louis lawyer. Melrose had a curvilinear street pattern (undoubtedly influenced by the terrain) reminiscent of Frederick Law Olmsted's Riverside, Illinois, but 15 years earlier. Haven's ambitious layout included six public parks, special setbacks on some streets, and other amenities. Some streets were reserved to be private places. Haven built his own home, called Woodlawn, in Melrose, and worked hard to attract other buyers, but few improvements were ever made. A three-story frame seminary for young ladies was constructed, but that institution succumbed during the Civil War although the building survived in other uses until after 1915. The deeds that Haven issued to property owners stated that the owner had to build a dwelling and construct a fence on the property within one year, or the property reverted back to the developer.³

According to one account, Haven "promoted the area like a present day subdivision developer. He brought train loads of St. Louisans out to the end of the tracks, Glencoe station, where they were met by a

¹ Lewis G. Atherton, The Southern Country Store, 1800-1860 (New York: Greenwood Press, 1968 reprint), p.65.

² The surveys were funded by Historic Preservation Fund grants administered by the Historic Preservation Program of the Missouri Department of Natural Resources.

³ Information about the development of Melrose is from various sources including J. Thomas Scharf, History of St. Louis City and County from the Earliest Period to the Present Day (Philadelphia: Louis H. Everts, 1883), p.1926; William L. Thomas, History of Saint Louis County, Missouri (St. Louis: St. Louis: The S. J. Clarke Publishing Co., 1911, Vol. II), pp. 311-312; and The Watchman Advocate History of St. Louis County (Clayton, Missouri: Watchman Advocate, 1919), pp. 89, 106.

United States Department of the Interior
National Park Service

National Register of Historic Places
Continuation Sheet

Section 8 Page 9

Kreienkamp Store
St. Louis County, Missouri

brass band, and taken to Melrose by horse and carriage. Lots...were sold by auction, and persons who purchased lots were required to fence them immediately to 'enhance the beauty' of the area."⁴

The first post office was opened at Melrose in 1858.⁵ In 1859, Haven's Melrose holdings were reorganized into a corporation known as the St. Louis Vine & Fruitgrowers Association; prominent investors included the Czar of Russia's son. Part of the wine cellar for that project is intact and is located on property near the Kreienkamp Store. Land speculators Christy & Woods bought property in the area and planned a rail line from the Meramec River at Glencoe to the Missouri River at St. Albans, but the project was abandoned when the Pacific Railroad was routed through Gray Summit eight miles to the west. Haven apparently lost much of his property during the Civil War, while the lack of a local railroad probably sealed the demise of Melrose as a planned community.⁶ In 1879 the holdings of the St. Louis Vine & Fruitgrowers corporation were sold at a tax sale to John and Mary Wildberger.⁷ An 1876 atlas indicates those parcels in central Melrose that were purchased and improved, and not included in the tax sale. In 1885 Melrose, then encompassing approximately 110 acres, was purchased by a local farmer and Civil War veteran, C. Julius Hardt.⁸ Hardt moved into Woodlawn, the former home of community developer Charles Haven.⁹

In 1995 Melrose, along with a number of other small communities distributed over approximately 69 square miles of western St. Louis County, was incorporated into the city of Wildwood.

Elaboration/Commerce: The Kreienkamp Store is locally significant in the area of Commerce because of its long history (more than a century) as a general store in the planned community of Melrose. Although Melrose presumably failed as an urban community because of its relative isolation, this isolation strengthened the store's importance within the surrounding rural community. Because it also housed the Melrose post office and was a stagecoach stop, the Kreienkamp Store provided the area's primary linkage with the outside world. The store's relatively large size accommodated both commercial and social functions, enabling it to fulfill important community needs over a period of several decades in both the 19th and 20th centuries.

As James M. Mayo noted in The American Grocery Store: The Business Evolution of an Architectural

⁴ "Rollin' Along," Ellisville Community Press, July 17, 1968.

⁵ Robert G. Schulte, Missouri Post Offices, 1804-1981, 1982.

⁶ Sophie Kreienkamp, personal interview by Lynne Martin, September 18, 1988. Sophie Kreienkamp, interviewed at age 96, was the daughter of John Bartold, a lifelong resident of the Melrose area who told her about the log store and described where it stood. Sophie Kreienkamp was married to a nephew of Herman Kreienkamp.

⁷ Deed recorded in St. Louis County Records Book 8, p.164.

⁸ Deed recorded in St. Louis County Records Book 28, p.244.

⁹ Elinore Eatherton, personal interview by Lynne Martin, April 12, 1997. Elinore Eatherton is C. Julius Hardt's granddaughter.

United States Department of the Interior
National Park Service

National Register of Historic Places
Continuation Sheet

Section 8 Page 10

Kreienkamp Store
St. Louis County, Missouri

Space, "In the settlement and frontier expansion of the United States, the country store was both a commercial outlet and the local community center as it was in more settled areas in the East. Receiving mail was a settler's contact with the outside world, and the trip to visit the post office and to go shopping was the community world. It was a time to hear local gossip and to sustain friendships.....Beyond its established commercial functions, the store was a communication center."¹⁰

After Haven, the next owner of the property on which the Kreienkamp Store stands was Samuel Sides, a St. Louis confectionery owner who in 1854 purchased several lots in the development for \$150. Sides apparently constructed the original store, which was a one-story log building like most early American country stores, as well as the front-gabled portion of the present building. Sides lived in St. Louis according to census and city directory records, and appears to have rented out the store.¹¹ Most of the lots purchased by Sides reverted back to Haven, but Sides retained Lots 14 and 15 on De Soto Avenue (known today as Ossenfort Road) on which the Kreienkamp Store was constructed. De Soto Avenue was likened on the Melrose plat map to Lucas Place, an affluent private street in St. Louis. In about 1860, a two-story frame building was built directly east of, and attached to, the original one-story log store. It is this 20' x 36' building, with living quarters upstairs, that survives as the front-gabled portion of the present Kreienkamp Store.¹²

In the spring of 1874, Sides sold Lots 14 and 15 to Philip Walter and his wife Mary Elizabeth (Kreienkamp) Walter for \$175.¹³ Philip Walter was the postmaster at Melrose from 1870-1872, at which time Lydia Bischoff became postmaster. One month later the Walters sold the two lots, at a profit of \$1,925, to Mary's brother, Herman Kreienkamp.¹⁴ During a period of ownership that spanned several decades, Herman Kreienkamp sold the store, repurchased it, rented it out, and eventually made it his long-time home. Kreienkamp's ownership is documented by tax receipts from 1877 to 1936.

Born in 1847, Herman Kreienkamp was a son of Jobst Kreienkamp (1817-1882) who migrated from Germany to Missouri in 1844. The Kreienkamps settled in Franklin County and later expanded their farm into adjacent St. Louis County. Herman Kreienkamp's first participation in the development of Melrose apparently involved the planting of grape arbors and fruit trees in the local orchard, not far from the Kreienkamp Store, at about the age of 15.¹⁵

Kreienkamp's involvement in the store's operation varied during the early years. He ran the store for at

¹⁰ James M. Mayo, The American Grocery Store (Westport, Connecticut: Greenwood Press, 1993), p.59.

¹¹ Deed recorded in St. Louis City Records Book Y6, p.475.

¹² Sophie Kreienkamp, op cit. Also noted in Ellisville Community Press, op cit.

¹³ Deed recorded in St. Louis City Records Book 496, p.487, and Book 498, p.48.

¹⁴ Deed recorded in St. Louis City Records Book 491, p.408, and Book 500, p.261.

¹⁵ "Rollin' Along," Ellisville Community Press, July 17, 1968.

United States Department of the Interior
National Park Service

National Register of Historic Places
Continuation Sheet

Section 8 Page 11

Kreienkamp Store
St. Louis County, Missouri

least two years in the early 1870s before selling it to Lydia Bischoff and Carolina Hagemeyer.¹⁶ He repurchased it from Lydia and Fritz Bischoff three years later.¹⁷ Kreienkamp, who also farmed, proceeded to rent out the store to various proprietors including Louis Wachter, Emil Hardt, and Franklin Gaebler.¹⁸ In 1877 Kreienkamp married Mina Caesar, a student at the local Melrose Boarding School, but apparently the couple lived somewhere other than above the store during the early period of their marriage. The store probably became known as the Kreienkamp Store in the 1870s but its earlier name or names (possibly the Melrose Store or Sides' Store) has not been determined.

In 1883, Scharf's History of St. Louis and St. Louis County described the Kreienkamp Store as a "handsome new frame building" occupied by one "Louis Wackher, Postmaster."¹⁹ U.S. postal records indicate that the Kreienkamp Store housed an official postmaster and the Melrose Post Office from 1858 to 1904.²⁰ The store served as a drop site for mail for many years afterward.

The "new frame building" mentioned by Scharf was apparently a half-story addition and new siding on the original one-story log structure, depicted in a circa 1890 photograph at the approximate location of the present wing. This second floor addition provided a meeting place for Grand Army of the Republic Post 152 that organized at Melrose in 1882. Members of Post 152 met at the Kreienkamp Store until at least 1918 when the group disbanded, leaving behind numerous flags, swords, bayonets and other possessions.²¹ The large upstairs meeting area was also used as a dance hall for the community. Serving as a public meeting place for so long, Kreienkamp's percentage of non-store area was much greater than that of most other general stores. Perhaps because of its rural location and infrequent delivery schedules, Kreienkamp's also had a relatively large area set aside specifically for use as a warehouse.

During Emil Hardt's period as store operator, the Kreienkamp Store was listed in the 1889-90 edition of the Missouri State Gazetteer as a stagecoach stop 33 miles west of downtown St. Louis. Hardt, a son of C. Julius Hardt, the farmer and Civil War veteran who purchased 110 acres of the Melrose development in 1885, rented the store from Herman Kreienkamp for several years beginning in 1886.²²

¹⁶ Deed recorded in St. Louis City Records Book 512, p.512.

¹⁷ Deed recorded in St. Louis County Records Book 8, p.579.

¹⁸ Missouri State Gazetteer, 1876-77, 1881, 1883-84, 1885-86, 1889-90.

¹⁹ Louis J. Scharf, History of St. Louis City and County from the Earliest Period to the Present Day (Philadelphia: Louis H. Everts & Co., 1883), p.1926. Curiously, although mentioned in both Scharf and the Missouri State Gazetteer as the Melrose postmaster, Louis Wachter was never listed as postmaster in the U.S. Postal Records. The postmaster of record for Melrose from 1872-1886 was Lydia Bischoff, although various issues of the St. Louis city directory indicate that she maintained her residence in St. Louis.

²⁰ Postal records for Melrose are on file at the National Archive Records Center, Kansas City, Missouri.

²¹ Dorothy Mae (Brommelsick) Rankin, interviewed by Lynne Martin, August 18, 1991. Ms. Rankin is a granddaughter of Herman Kreienkamp. Those war relics were sold at auction in September 1987.

²² Watchman Advocate History of St. Louis County (Clayton, Missouri: Watchman Advocate Publishing Co.), 1989.

United States Department of the Interior
National Park Service

National Register of Historic Places
Continuation Sheet

Section 8 Page 12

Kreienkamp Store
St. Louis County, Missouri

Due to the ultimate failure of Melrose and the subsequent tax sale, the property descriptions used for the few pieces not included in that sale apparently were in question. In 1896 Herman Kreienkamp filed a quit claim deed on Lots 14 and 15 at Melrose, then bought nine acres that included Lots 14 and 15 from Julius Hardt.²³ Soon after this, Kreienkamp moved his family into the store and proceeded to become Melrose's leading merchant.

The building's present appearance was achieved between 1897 and 1915. During this period, the building's traditional storefront with a central entrance flanked by display windows was created. In the process, a transom above the main entrance was removed and the front doors were replaced with taller doors. Square, beveled porch supports were replaced with the present turned supports, the porch roof was added, and a new balustrade was installed on the balcony. This reduced the building's Greekness while facilitating its effectiveness as a market. Also during this period, the original log store and the meeting hall for the G.A.R. was completely rebuilt. The new wing continued to serve as a meeting hall until Otto Jobst Kreienkamp, Herman Kreienkamp's son, divided part of the second floor into living quarters for his parents around 1918. The westernmost portion of the first floor continued to be used as a warehouse until 1950. The westernmost portion of the second floor continued to be used as a polling place for the west half of Meramec Township into the 1960s until newly-introduced polling machines could not be carried up the narrow stairway.²⁴

While the store's original builder is unknown, Walter Schlemper, a local carpenter and furniture maker who married Herman Kreienkamp's sister Emma, apparently did much of the remodeling for Kreienkamp in the late 1890s or early 1900s. Schlemper signed his work by writing his name on the inside of a wall on the second floor of the residential addition.²⁵

In 1918 Herman Kreienkamp retired and turned the business over to his son, Otto, with the stipulation that the young man take care of his mother. Herman Kreienkamp died in 1924, and his wife Mina passed away in 1937. After Otto Kreienkamp died in 1951, Otto's wife Elizabeth continued as the owner and the store was operated by their children, Ralph Otto and Mae Elizabeth Kreienkamp. The importance of the store diminished greatly in the late 1940s when a new "St. Albans Road" (Highway T) diverted traffic from Melrose Road, but the Kreienkamp children nonetheless operated the store until they retired in 1978.²⁶

The Kreienkamp Store's commercial success can also be evaluated by the number and variety of goods sold and traded, and transactions with other businesses in the St. Louis area. In regions of scattered

²³ St. Louis County Record Book 88, p.236.

²⁴ Ralph Kreienkamp, interviewed by Lynne Martin, June 3, 1992. Ralph Kreienkamp is the son of Otto Kreienkamp.

²⁵ Schlemper's name was discovered when a bathroom was remodeled in 1988.

²⁶ Dorothy Mae Rankin, op cit.

United States Department of the Interior
National Park Service

National Register of Historic Places
Continuation Sheet

Section 8 Page 13

Kreienkamp Store
St. Louis County, Missouri

population or low purchasing power, storekeepers had to carry a general range of merchandise as partial compensation for the limited extent of the market.²⁷ Throughout the store's history, there appear to have been numerous connections with mercantile operators and businessmen in the City of St. Louis. As noted by Atherton in The Southern Country Store, 1800-1860, this typical relationship was mutually advantageous. The more rural location could act as a gathering and shipping point for raw goods, livestock and produce, while the "city store" could provide quick access to manufactured and finished goods. In some cases the associated city stores provided credit and acted as wholesalers to the rural outlets that had a more captive clientele, as the generally poor condition of local roads discouraged frequent trips to city markets.²⁸

From 1892-94, ledgers kept by storekeeper Franklin G. Gaebler indexed the customer's names on the first page and next to their name listed the pages on which their specific activities could be found. Because he was renting from Herman Kreienkamp, Gaebler also entered his rent payment, the day paid and the amount every three months. A ledger kept by the Kreienkamps for 1898-99 lists daily transactions of goods sold and traded, their price and the patron's identification number. This number was used to cross-reference the patron's account described in another journal. Merchandise purchased in December 1898 included basic cooking and baking supplies, candies, fruit, and sardines. Personal items recorded in the ledger ranged from hairpins to shoes. A variety of cloth material such as muslin, gingham, chambray, sateen, and a more expensive "chasmire" (presumably cashmere) sold for 65-cents per yard. Coal oil sold for 15-cents per gallon.

The Kreienkamps also bartered with customers who had little cash to pay for merchandise, accepting produce such as eggs, butter, milk, cheese, livestock and in some cases, labor, in exchange for merchandise. When livestock was traded a freight fee was charged to cover transportation costs to market. The first entry in Edna Kreienkamp's diary (Herman's daughter), from January 1, 1910, relates a hauling accident when her father "upset" the wagon and lost a number of goods about a mile east of the store.

The 1898 ledger reveals that in a typical week, patrons brought in over 250 dozen eggs for trade. As there was little local outlet for this product (nearly all rural residents kept chickens), the Kreienkamps were forced to transport this "cash crop" to the city. The Kreienkamps maintained delivery wagons, and later a motor truck, to haul livestock and produce taken in trade. To take best advantage of these trips, the Kreienkamps returned with a load of city merchandise for their rural store. Receipts from 1912 for cleaning and hauling services apparently indicate an expansion of commercial activities.

Although subject to fluctuating conditions in distant markets, a rural store such as the Kreienkamp Store

²⁷ Atherton, op cit., p. 74.

²⁸ Atherton, op cit., p. 88.

United States Department of the Interior
National Park Service

National Register of Historic Places
Continuation Sheet

Section 8 Page 14

Kreienkamp Store
St. Louis County, Missouri

could be at least a modestly profitable monopoly for the shopkeeper willing to put in long hours in the years before better roads, reliable automobiles and prepackaged products. But of greatest importance, rural general stores were hubs of activity, social as well as commercial, and anchors in the communities they served.

Elaboration/Architecture: The Kreienkamp Store is a well-preserved example of a 19th century general store with modest Greek Revival influences. The simple description of this building as an old general store is also a partial statement of its significance; such buildings are representative of a dwindling resource type in Missouri. The Kreienkamp Store follows Lewis E. Atherton's typology for the Southern country store in that it evolved over time from a one-story log building to its present configuration in order to meet the needs of the owners while serving the larger community and accommodating changes in marketing.²⁹ While the main block (with the Greek Revival features) dates from circa 1860, the two-story wing apparently was constructed after Herman Kreienkamp moved into the store with his family in about 1897. Over the years, and typically for a general store in a rural location, the Kreienkamp Store also served as a post office, stagecoach stop and community meeting place for Civil War veterans and other local groups. When display windows were installed between 1897 and 1915, this enabled food products and other merchandise to be viewed by travelers on nearby Melrose Road, perhaps tempting them to stop. For at least the past 85 years, however, the form of the Kreienkamp Store has been relatively unchanged.

The store's entrance has always been in the gabled end of the building, an identifying feature even before the installation of display windows. As Mayo noted, the country store's exterior was an important part of its image: "In many regions, and most certainly in the South, the store's façade was a square front, and this design became a badge of the trade much like a barber shop displaying a tri-colored pole of red, white, and blue."³⁰ When the Kreienkamp Store's front gable is discounted, the storefront is very nearly square. Residents of the Melrose area certainly were well aware of the store's existence but when it came to attracting travelers in the years before display windows, the Kreienkamp Store probably benefited from this "badge of the trade" because no exterior signage is visible in historic photographs.

The Kreienkamp Store is a fine transitional example of balloon frame construction, in that the carpenter chose to rely on older methods for the wall's key components. The oak corner posts, let-in bracing, and log joists on the first floor are representative of traditional post-and-beam methods, while the remaining walls, second floor joists, and roof framing were done according to the principles of balloon-frame construction. Originating in Chicago in 1833, the balloon-frame system did not fully evolve until almost

²⁹ Atherton, *op cit.*, p.65.

³⁰ James M. Mayo, The American Grocery Store: The Business Evolution of an Architectural Space (Westport, Connecticut: Greenwood Press, 1993), p.65.

United States Department of the Interior
National Park Service

National Register of Historic Places
Continuation Sheet

Section 8 Page 15

Kreienkamp Store
St. Louis County, Missouri

1880.³¹ The store was built over an unusually tall and solid stone foundation. Although a somewhat different location would have allowed for a natural walk-out basement, the builder excavated a complete basement nearly nine feet tall. The most likely reason for this was that the resulting cool storage area could be used not only for produce but also as a wine cellar, as many acres of grapes were planted nearby and converted into wine in the late 1850s and early 1860s. The building's evolution was completed with construction of the wing, which replaced a log building in which the earliest Melrose store had been located.

While the Kreienkamp Store perhaps should not be described as a Greek Revival-style building, Greek Revival influences are obvious. McAlester and McAlester described six Greek Revival subtypes on the basis of their form and Greek Revival affinities, and the Kreienkamp Store is a modest vernacular example of the Gable Front and Wing subtype.³² The style is most evident in a historic view dating from between circa 1886 and 1890, at which time the entrance was topped with a multi-light transom and apparently had sidelights on only one half of the doorway, an uncommon variation. But other elements of the style are present today, most notably flattened triangular door and window openings and cornice returns in the building's three gabled ends, all suggesting pediments. The scrollwork balustrade on the upstairs porch is an appropriate Greek Revival type in Missouri, and window sashes with six-pane glazing have been commonly associated with the Greek Revival (as well as the Adam) style. The present turned porch supports are Victorian, but the original posts (seen in the historic view) were square with chamfered edges, a characteristic type on many vernacular examples in Missouri.

The interior plan of the Kreienkamp Store was shaped by the building's multiple functions as general store, post office, residence, meeting hall, and stagecoach stop. The main floor of the store portion consisted of one large room, as currently, which provided a sufficient amount of space for the store/post office/stagecoach stop functions. Shelves and counters were arranged along the sides and probably within the central area. Although the building is a private residence today, the main floor retains elements of its appearance at around the turn of the century including a ceiling of decorative pressed metal, original wainscoting and flooring; historic shelving is also present. Living quarters above the store meant that the Kreienkamps and earlier operators were never far from their work and so did not have to "man" the store continually, as an hour or more might elapse between customers. Household tasks as well as at least limited farm or gardening chores could be accomplished during business hours. A bell system, later converted to electricity, alerted the storekeeper that the front door had been opened. The Kreienkamp children slept in an attic room. The wing featured a public meeting hall and a polling place upstairs, while the first floor had various uses including storage. The basement was also suitable for the storage of produce.

³¹ Fred W. Peterson, Homes in the Heartland (Lawrence: University Press of Kansas, 1992), p.14.

³² Virginia and Lee McAlester, A Field Guide to American Houses (New York: Alfred A. Knopf, 1985), pp. 178-193.

United States Department of the Interior
National Park Service

National Register of Historic Places
Continuation Sheet

Section 8 Page 16

Kreienkamp Store
St. Louis County, Missouri

Standing on its original site, the Kreienkamp Store is the least altered of five extant general stores established in St. Louis County between 1860 and 1918 that have been identified as significant examples of this property type. The others are the Hoppenberg-Fick Store (1866), Barlbort's General Merchandise Store (1895), the Kassebaum Building (1913) and Zierenberg Mercantile (1918). Each store's operation exhibits characteristics representative of general stores in 19th and early 20th century settlements. Of these, the Kassebaum and Zierenberg buildings are brick while Barlbort's and Hoppenberg-Fick are frame like the Kreienkamp Store. Located on main arteries in urban areas, Barlbort's, Kassebaum and Zierenberg all have modern additions. Barlbort's and Zierenberg are currently unoccupied and their futures are uncertain. Only Kreienkamp and Hoppenberg-Fick exist within relatively rural settings and continue to serve as single dwellings although, unfortunately, Hoppenberg-Fick appears threatened from nearby development and also has been more extensively altered the Kreienkamp Store. In addition to being the least altered of the five, the Kreienkamp Store also is unique for its long period of continuous use, functioning as a general store until 1978.³³ Changes made to expand and improve its operation have maintained the property's historic character.

Both the Kreienkamp and Hoppenberg-Fick properties are located in Wildwood, a recently formed city in western St. Louis County. The former community of Melrose, along with various other small communities, was incorporated into the new city. Wildwood has adopted a historic preservation ordinance that, among other things, should be beneficial in connection with the adaptive reuse of commercial and other properties.

Although no longer operated as a general store, the Kreienkamp Store retains the ambiance of its period of significance and merits listing in the National Register of Historic Places.
produce.

³³ The general stores were identified in surveys conducted in the 1980s by the St. Louis County Department of Parks & Recreation. Addresses of the other four stores are: Hoppenberg-Fick Store, Old Eatherton Road; Balbort's General Merchandise Store, 12204 Bellefontaine Road; Kassebaum Building, 5049 Lemay Ferry Road; and Zierenberg Mercantile, 14151 Olive Boulevard.

United States Department of the Interior
National Park Service

National Register of Historic Places
Continuation Sheet

Section 8 Page 17

Krelenkamp Store
St. Louis County, Missouri

Figure 4: Charles Haven's Plat of Melrose

103

CENTRAL MELROSE
Sec. 7 & 8, T. 44 R. 3 E. 1a
by Chas. Haven

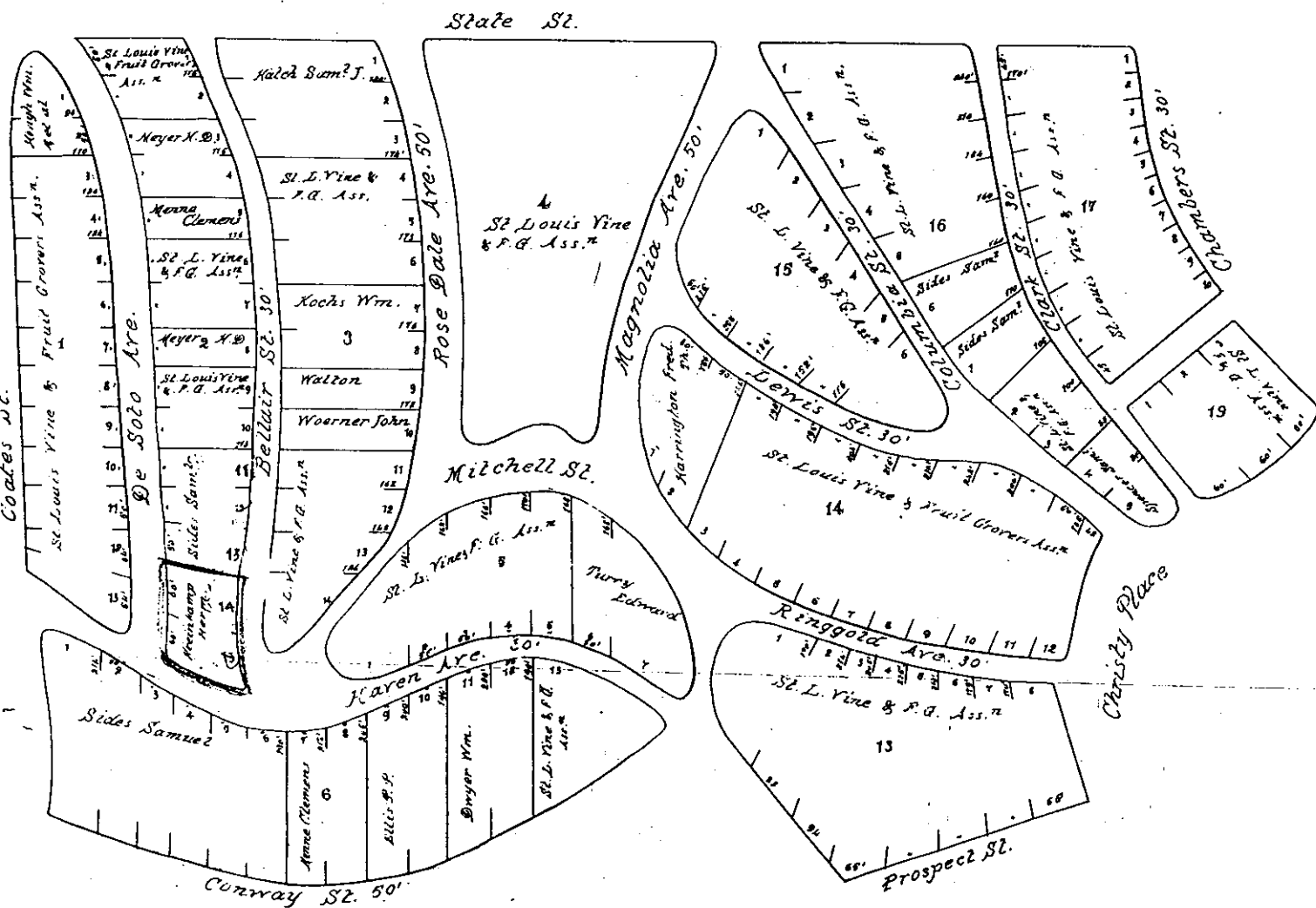

Source: 1876 County of St. Louis Plat Book

United States Department of the Interior
National Park Service

National Register of Historic Places
Continuation Sheet

Section 9 Page 18

Kreienkamp Store
St. Louis County, Missouri

Bibliography

- Atherton, Lewis. The Southern Country Store, 1800-1860. New York: Greenwood Press, 1968.
- Gaebler, F. G. Melrose Store Ledger Book, 1891-1894. (Unpublished.)
- Gottfried, H. and J. Jennings. American Vernacular Design, 1870-1940. Ames, Iowa: Iowa State University Press, 1985.
- Kreienkamp, Edna. Personal Diary, 1910. (Unpublished.)
- Kreienkamp, Herman. Melrose Store Ledger Book, 1897-98. (Unpublished.)
- Mayo, James M. The American Grocery Store: The Business Evolution of an Architectural Space. Westport, Connecticut: Greenwood Press, 1993.
- McAlester, Virginia and Lee. A Field Guide to American Houses. New York: Alfred A. Knopf, 1984.
- Missouri State Gazetteer, 1876-77; 1881; 1883-84; 1885-86; 1889-90.
- Peterson, Fred W. Homes in the Heartland. Lawrence: University Press of Kansas, 1992.
- Reiner, Verna. "Country Stores: Year-Round Friendliness." Lafayette News, May 19, 1976.
- "Rollin' Along." Ellisville Community Press, July 17, 1968.
- Scharf, J. Thomas. History of St. Louis City and County. Philadelphia: Louis H. Everts, 1883.
- Schulte, Robert G. Missouri Post Offices, 1804-1981, 1982.
- U.S. Postal Records, National Archive Central Record Center, Kansas City, Missouri.
- Watchman Advocate. History of St. Louis County. Clayton: Watchman Advocate, 1920.
- Deeds:
- Deed recorded in St. Louis County Book 28, page 244.
- Deed recorded in St. Louis County Book 8, page 164.
- Deed recorded in St. Louis City records, Book Y6, page 475.
- Deed recorded in St. Louis City records, Book 496, page 487, and Book 498, page 48.

United States Department of the Interior
National Park Service

National Register of Historic Places
Continuation Sheet

Section 9, 10 Page 19

Kreienkamp Store
St. Louis County, Missouri

Deed recorded in St. Louis City records, Book 491, page 408, and Book 500, page 261.

General warranty deed recorded in St. Louis City records, Book 512, page 512.

Deed recorded in St. Louis County records, Book 8, page 579.

Quit claim deed and purchase of ground recorded in St. Louis County records, Book 88, page 236.

Interviews:

Kreienkamp, Sophie. Wife of Herman Kreienkamp's nephew. Interviewed by Jim and Lynne Martin, September 18, 1988. Notes kept at Kreienkamp Store.

Rankin, Dorothy Mae (Brommelsick). Granddaughter of Herman Kreienkamp. Interviewed by Jim and Lynne Martin, August 18, 1991. Notes kept at Kreienkamp Store.

Kreienkamp, Ralph. Grandson of Herman Kreienkamp. Interviewed by Lynne Martin, June 3, 1992. Notes kept at Kreienkamp Store.

Eatherton, Elinore. Granddaughter of C. Julius Hardt. Interviewed by Lynne Martin, April 12, 1997. Notes kept at Kreienkamp Store.

Geographical Data

Verbal Boundary Description

The boundary of the Kreienkamp Store is shown as the dotted line on accompanying Map No. 24Y, St. Louis County Department of Revenue, dated August 30, 1999. The roughly triangular shaped tract is in the north portion of Lot A (Parcel #0128), Big Tree Subdivision, St. Louis County, Missouri. Beginning at Point A, proceed approximately southeast for 443.71 feet along the right-of-way of Melrose Road to Point B, then continue approximately southwest for 16 feet along the eastern boundary of Lot A to Point C, then continue west 392 feet to the western boundary of Lot A to Point D, then continue north 211 feet along the western boundary of Lot A to the point of origin.

Boundary Justification

The described tract encompasses the historic site of the Kreienkamp Store as it appeared to travelers approaching from either direction on Melrose Road. South of the C-D line, Lot A contains properties that would be noncontributing.

**United States Department of the Interior
National Park Service**

**National Register of Historic Places
Continuation Sheet**

Section 11 Page 20

**Kreienkamp Store
St. Louis County, Missouri**

11. Form Prepared By

1. Jim and Lynne Martin (preliminary draft by Dawn Yvonne McMartin, 1990)
Wildwood Historical Society, Lynne Martin, President
19160 Melrose Road
Wildwood, Missouri 63038
Date: January 9, 2000
Telephone: 636/458-3306
Original preparer(s)

2. Roger Maserang
Historian
Department of Natural Resources
Historic Preservation Program
P.O. Box 176
Jefferson City, Missouri 65102
Date: March 9, 2000
Telephone: 573/522-4641
Editor and revisions

**United States Department of the Interior
National Park Service**

**National Register of Historic Places
Continuation Sheet**

Section Photographs Page 21

**Kreienkamp Store
St. Louis County, Missouri**

Photographs

The following information is the same for all photographs except as noted:

Kreienkamp Store

Wildwood, St. Louis County, Missouri

Photographer: Lynne Martin (1-3); Esley Hamilton (4); Edna Kreienkamp (5-6); Unknown (7); M. W. Keller (8)

Date: January 2000 (1-3); March 1988 (4); circa 1915 (5-6); circa 1897 (7); circa 1886-1890 (8)

Location of Negatives: 19160 Melrose Road, Wildwood, Missouri

Description of Photographs:

1. Southeast and northeast facades, facing southwest across Melrose Road.
2. Northeast and northwest facades, facing southeast across Melrose Road.
3. Southwest façade, facing northeast.
4. Southeast and northeast facades, facing southwest across Melrose Road.
5. Historic view of northeast façade, facing southwest.
6. Historic view of southeast façade, looking approximately west along unpaved Melrose Road.
7. Historic view of southeast and northeast facades, facing southwest.
8. Historic view of northeast façade, facing southwest.

Kreierhaus Fire

1910

Wildwood vicinity, St. Louis Co., MO

UTM Reference

5-698560E, 4271540N

















