

United States Department of the Interior
National Park Service

National Register of Historic Places Registration Form

This form is for use in nominating or requesting determinations for individual properties and districts. See instructions in National Register Bulletin, *How to Complete the National Register of Historic Places Registration Form*. If any item does not apply to the property being documented, enter "N/A" for "not applicable." For functions, architectural classification, materials, and areas of significance, enter only categories and subcategories from the instructions. Place additional certification comments, entries, and narrative items on continuation sheets if needed (NPS Form 10-900a).

1. Name of Property

Historic name Hotel Cuba

Other names/site number Palace Hotel, Cuba Hotel

Name of related Multiple Property Listing Historical and Architectural Resources of the City of Cuba, Missouri, 1821-1963

2. Location

Street & number 600 East Main Street

N/A	not for publication
-----	---------------------

City or town Cuba

N/A	vicinity
-----	----------

State Missouri Code MO County Crawford Code 055 Zip code 65453

3. State/Federal Agency Certification

As the designated authority under the National Historic Preservation Act, as amended,
I hereby certify that this nomination request for determination of eligibility meets the documentation standards for registering properties in the National Register of Historic Places and meets the procedural and professional requirements set forth in 36 CFR Part 60.

In my opinion, the property meets does not meet the National Register Criteria. I recommend that this property be considered significant at the following level(s) of significance:

national statewide local

Applicable National Register Criteria: A B C D

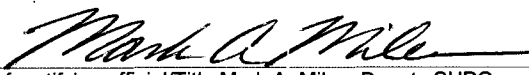
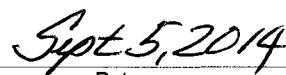
Signature of certifying official/Title Mark A. Miles, Deputy SHPO

Date

Missouri Department of Natural Resources

State or Federal agency/bureau or Tribal Government

In my opinion, the property meets does not meet the National Register criteria.

Signature of commenting official

Date

Title

State or Federal agency/bureau or Tribal Government

4. National Park Service Certification

I hereby certify that this property is:

entered in the National Register determined eligible for the National Register

determined not eligible for the National Register removed from the National Register

other (explain:)

Signature of the Keeper

Date of Action

Hotel Cuba
Name of Property

Crawford County, Missouri
County and State

5. Classification

Ownership of Property
(Check as many boxes as apply.)

Category of Property
(Check only **one** box.)

Number of Resources within Property
(Do not include previously listed resources in the count.)

<input checked="" type="checkbox"/>	private
<input type="checkbox"/>	public - Local
<input type="checkbox"/>	public - State
<input type="checkbox"/>	public - Federal

<input checked="" type="checkbox"/>	building(s)
<input type="checkbox"/>	district
<input type="checkbox"/>	site
<input type="checkbox"/>	structure
<input type="checkbox"/>	object

<u>Contributing</u>	<u>Noncontributing</u>	
1		buildings
		sites
		structures
		objects
1		Total

Number of contributing resources previously listed in the National Register

0

6. Function or Use

Historic Functions
(Enter categories from instructions.)

Current Functions
(Enter categories from instructions.)

DOMESTIC/Hotel

DOMESTIC/Multiple Dwelling/Apartment

7. Description

Architectural Classification
(Enter categories from instructions.)

Materials
(Enter categories from instructions.)

Late 19th and Early 20th Century American
Movements

foundation: Concrete

walls: Brick

roof: Asphalt

other: Glass

NARRATIVE DESCRIPTION ON CONTINUATION PAGES

Hotel Cuba
Name of Property

Crawford County, Missouri
County and State

8. Statement of Significance

Applicable National Register Criteria

(Mark "x" in one or more boxes for the criteria qualifying the property for National Register listing.)

- A Property is associated with events that have made a significant contribution to the broad patterns of our history.
- B Property is associated with the lives of persons significant in our past.
- C Property embodies the distinctive characteristics of a type, period, or method of construction or represents the work of a master, or possesses high artistic values, or represents a significant and distinguishable entity whose components lack individual distinction.
- D Property has yielded, or is likely to yield, information important in prehistory or history.

Criteria Considerations

(Mark "x" in all the boxes that apply.)

Property is:

- A Owned by a religious institution or used for religious purposes.
- B removed from its original location.
- C a birthplace or grave.
- D a cemetery.
- E a reconstructed building, object, or structure.
- F a commemorative property.
- G less than 50 years old or achieving significance within the past 50 years.

STATEMENT OF SIGNIFICANCE ON CONTINUATION PAGES

Areas of Significance

COMMERCE

Period of Significance

1915-1926

Significant Dates

1915: original hotel opens
1926: modified to Route 66

Significant Person

(Complete only if Criterion B is marked above.)

N/A

Cultural Affiliation

N/A

Architect/Builder

Unknown

9. Major Bibliographical References

Bibliography (Cite the books, articles, and other sources used in preparing this form.)

Previous documentation on file (NPS):

- preliminary determination of individual listing (36 CFR 67 has been requested)
- previously listed in the National Register
- previously determined eligible by the National Register
- designated a National Historic Landmark
- recorded by Historic American Buildings Survey # _____
- recorded by Historic American Engineering Record # _____
- recorded by Historic American Landscape Survey # _____

Primary location of additional data:

- State Historic Preservation Office
- Other State agency
- Federal agency
- Local government
- University
- Other

Name of repository: Cuba Historical Society

Historic Resources Survey Number (if assigned): _____

10. Geographical Data

Hotel Cuba
Name of Property

Crawford County, Missouri
County and State

Acreage of Property Under 1 acre

Latitude/Longitude Coordinates

Datum if other than WGS84: _____
(enter coordinates to 6 decimal places)

1 38.063231 -91.399080 3 _____
Latitude: Longitude: Latitude: Longitude:

2 _____ 4 _____
Latitude: Longitude: Latitude: Longitude:

UTM References

(Place additional UTM references on a continuation sheet.)

_____ NAD 1927 or _____ NAD 1983

1 _____
Zone Easting Northing

3 _____
Zone Easting Northing

2 _____
Zone Easting Northing

4 _____
Zone Easting Northing

Verbal Boundary Description (On continuation sheet)

Boundary Justification (On continuation sheet)

11. Form Prepared By

name/title Matt Bivens/Historic Preservation Director

organization Lafser & Associates, Inc.

date 1.31.14; REV 3.21.14; Fin8.15.2014

street & number 1215 Fern Ridge Pkwy., Suite 110

telephone 314-560-9903

city or town St. Louis

state MO

zip code 63141

e-mail msbivens@lafser.com

Additional Documentation

Submit the following items with the completed form:

- **Maps:**
 - A **USGS map** (7.5 or 15 minute series) indicating the property's location.
 - A **Sketch map** for historic districts and properties having large acreage or numerous resources. Key all photographs to this map.
- **Continuation Sheets**
- **Photographs**
- **Owner Name and Contact Information**
- **Additional items:** (Check with the SHPO or FPO for any additional items.)

Paperwork Reduction Act Statement: This information is being collected for applications to the National Register of Historic Places to nominate properties for listing or determine eligibility for listing, to list properties, and to amend existing listings. Response to this request is required to obtain a benefit in accordance with the National Historic Preservation Act, as amended (16 U.S.C.460 et seq.).

Estimated Burden Statement: Public reporting burden for this form is estimated to average 18 hours per response including time for reviewing instructions, gathering and maintaining data, and completing and reviewing the form. Direct comments regarding this burden estimate or any aspect of this form to the Office of Planning and Performance Management, U.S. Dept. of the Interior, 1849 C. Street, NW, Washington, DC.

Hotel Cuba

Name of Property

Crawford County, Missouri

County and State

Photographs

Submit clear and descriptive photographs. The size of each image must be 1600x1200 pixels (minimum), 3000x2000 preferred, at 300 ppi (pixels per inch) or larger. Key all photographs to the sketch map. Each photograph must be numbered and that number must correspond to the photograph number on the photo log. For simplicity, the name of the photographer, photo date, etc. may be listed once on the photograph log and doesn't need to be labeled on every photograph.

Photo Log:

Name of Property: Hotel Cuba

City or Vicinity: Cuba

County: Crawford State: Missouri

Photographer: David Monda; Susan Luksza & Heather Bullar

Date

Photographed: 1-25-2014; 3-19-2014

Description of Photograph(s) and number, include description of view indicating direction of camera:

- 1 of 11: Primary elevation to Railroad (right) and west elevation (left); camera facing northeast
- 2 of 11: Primary elevation to Railroad (left) and east elevation (right); camera facing northwest
- 3 of 11: Primary elevation to Route 66 (right) and east elevation (left); camera facing southwest
- 4 of 11: Primary elevation to Route 66 (left) and west elevation (right); camera facing southeast
- 5 of 11: Interior 1st floor entry; camera facing north
- 6 of 11: Interior 1st floor hall; camera facing north
- 7 of 11: Interior 1st floor unit; camera facing west
- 8 of 11: Interior 1st to 2nd floor stair; camera facing south
- 9 of 11: Interior 2nd floor hall; camera facing north
- 10 of 11: Interior 2nd floor unit; camera facing east
- 11 of 11: Interior 2nd floor unit; camera facing south

Figure Log:

Include figures on continuation pages at the end of the nomination.

Figure 1 (page 3): Building footprint at first (left) and second (right) floors. Source: Lafser site visit.

Figure 2 (page 6): Sanborn Fire Insurance Map, 1914. Shows earlier buildings on site demolished.

Figure 3 (page 6): Sanborn Fire Insurance Map, 1914. Shows earlier buildings on site demolished.

Figure 4 (page 7): Sanborn Fire Insurance Map, 1924. Site of nominated building as appeared prior to 1926.

Figure 5 (page 8): Postcard of the Hotel Cuba, Cuba, Missouri, ca. 1940.

National Register of Historic Places
Continuation Sheet

Section number 7 Page 1

Hotel Cuba
Name of Property
Crawford County, Missouri
County and State
Name of multiple listing (if applicable): Historical and Architectural Resources of the City of Cuba, Missouri, 1821-1963

ARCHITECTURAL DESCRIPTION

Summary

The Hotel Cuba located at 600 East Main Street in Cuba, Crawford County, Missouri, is a two-story, front parapet roof, rectangular-shaped building constructed of red brick and completed originally as the Palace Hotel in 1915. The building has a primary entrance to the south (in association with the railroad) and at the north (in association with Route 66). A flat roof porch on brick piers at the south elevation continues to the east; a second porch assembly is at the north. Multiple window penetrations in addition to entrances are at each elevation. A ghost sign "Hotel Cuba" is at the south parapet. The interior is currently used as rental apartments and is currently accessed via the Railroad entry at the south elevation. It contains long circulation corridors at the first and second stories with rooms radiating from the halls. The building is surrounded by a grassy area and parking lot and has sidewalk paving up to the entrance along the south. Although all of the windows are either replacement or boarded, the new infill respects the dimensions of the original fenestration. The building has sufficient integrity of location, design, setting, materials, workmanship, feeling and association.

Site

The Hotel Cuba occupies the southeast corner of a rectangular-shaped city block at the intersection of East Main Street and an un-named street. Mature trees are north of the Washington elevation. The lot surrounding the property is grass and gravel but otherwise not landscaped. Residential, institutional and commercial properties occupy the block.

Exterior

The Hotel Cuba is a two-story red brick structure with a primary entrance at the south (in association with the railroad); this symmetrical façade has a central door flanked by sidelights (photo 1). At either side are three windows, four are boarded while two have single replacement sash. A full width flat roof porch on brick posts with simple wood capitals shelters the façade. Above, a central door with access to the roof is flanked by a single sash replacement and a boarded window at either side. A band of brighter red brick bears the ghost sign "Hotel Cuba" under a projecting, but flat parapet roof (photos 1-2).

The porch wraps around to the east side and terminates at the fourth column above an entrance and replacement window. Columns have wider bases with concrete caps under ¼ height of the ground. Eleven additional replacement windows, either double-hung or boarded are at the first and second floors. Windows are of the same

National Register of Historic Places
Continuation Sheet

Section number 7 Page 2

Hotel Cuba
Name of Property
Crawford County, Missouri
County and State
Name of multiple listing (if applicable): Historical and Architectural Resources of the City of Cuba, Missouri, 1821-1963

size, both height and width and are set back from the brick (photo 2). An exposed concrete foundation supports the brick walls and a stepped parapet roof crowns the elevation (photos 2-3).

A one-story shaped parapet brick addition is at the north elevation (in association with Route 66) and has a similar flat roof porch on brick piers without widened bases. The porch shelters the facades beneath and extends outward from the footprint of the building above a concrete base to the north and east (photos 3 and 4). A replacement entrance door faces east in the one-story portion with paired double-hung replacement windows at either side. An additional similar entrance is at the north wall and is flanked at the right side by a pair of wider, similar windows and at the left by a pair of narrower and similar windows (photo 4). The west wall of the small addition has a closed in window and a smaller, double-hung replacement closest the original part of the building (photo 4). Above at the second story of the original building is an entrance flanked by a boarded window at either side with access on top of the lower addition roof (photo 4). A steep, side-gabled roof wraps the parapet (photos 3-4). The roof above is flat.

The west elevation is similar to the east in that it contains similar fenestration at the first and second floors underneath a stepped parapet roof (photo 4). The foundation is partially exposed towards the north and a basement access hatch is set at the ground level. The first floor contains a series of sixteen openings, two of which are slightly larger, boarded, and may correspond to additional entrances (photo 4). Three of the windows are boarded while the remainder has replacement, double-hung windows. The second floor has ten similar windows and none are boarded (photo 4). The roof parapet steps up to the south.

Interior

The interior is accessed via the original building address facing the railroad. Through a newer entrance with sidelights (photo 5) an entry hall leads to a stair to the 2nd floor and a long hall to access units (photo 6). Original hotel rooms have been converted to apartments (photo 7)—many enlarged from 2 hotel rooms into one apartment. Floors are vinyl and walls are both plaster and gypsum wall board. The long circulation corridor leads to the north of the building where a second stair also leads upstairs (photo 8). A similar long hall is flanked by multiple apartments on the 2nd floor (photo 9). Units are also similar to those on the first floor (photos 10-11). (Figure 1 on page 3 illustrates the floor plan).

National Register of Historic Places
Continuation Sheet

Section number 7 Page 3

Hotel Cuba
Name of Property
Crawford County, Missouri
County and State
Name of multiple listing (if applicable): Historical and Architectural Resources of the City of Cuba, Missouri, 1821-1963

Integrity

Although all of the windows are replacements, new windows respect the original openings and depths and fenestration patterns are clearly evident; few bays are boarded with removable materials. All of the brick from both the original 1915 building and the 1926 addition are intact as are exterior porches and balconies over brick piers. The original and historic footprints are intact as are the rooflines and pitches. The building retains its early signage "Hotel Cuba." Despite interior alterations of new materials covering floors and some interior demolition within rooms beyond circulation halls to expand small hotel rooms into apartments, the original feeling of the hotel is evident. The building has sufficient integrity of location, design, setting, materials, workmanship, feeling and association.

Figure 1: Building footprint at first (left) and second (right) floors. Source: Lafser site visit.

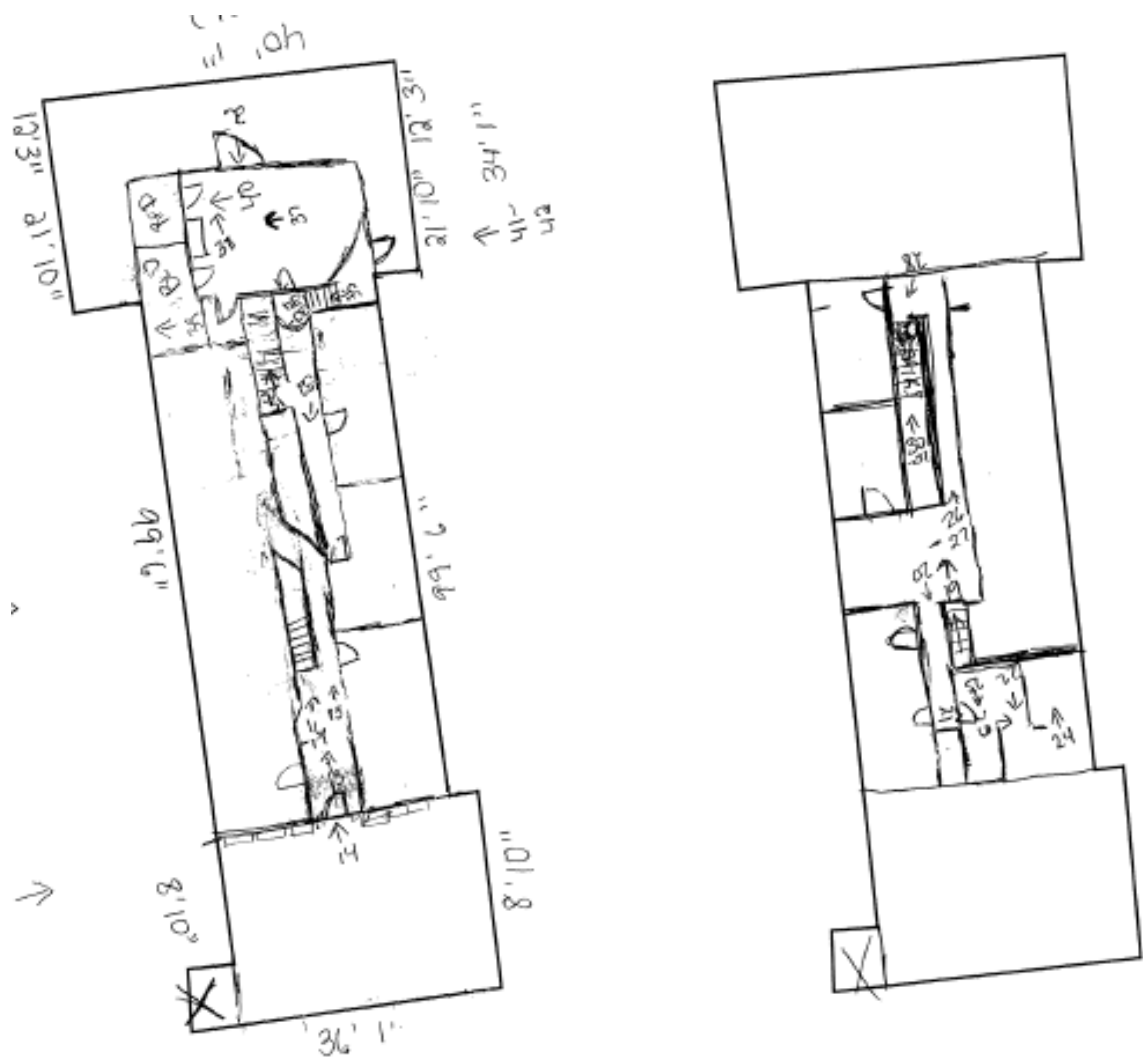

National Register of Historic Places
Continuation Sheet

Section number 8 Page 4

Hotel Cuba
Name of Property
Crawford County, Missouri
County and State
Name of multiple listing (if applicable): Historical and Architectural Resources of the City of Cuba, Missouri, 1821-1963

STATEMENT OF SIGNIFICANCE

Summary

The Hotel Cuba located at 600 East Main Street in Cuba, Crawford County, Missouri, is eligible for local listing in the National Register of Historic Places (NRHP) under Criterion A in COMMERCE. Completed in 1915 as the Palace Hotel, it was constructed to initially serve railroad travelers. Upon the designation of State Highway 14 through Cuba in 1926 as Route 66, the building was modified with an addition at the north elevation to attract the new motorists. After this period the building served both the railroad and automobile clientele. The period of significance begins with the construction date of 1915 and it extends to 1926 when the second and final addition was completed. Additional significance in conjunction with Route 66 continues through the arbitrary 50-year cut-off in 1964 for National Register significance but for purposes of this listing it has been shortened. After the 1960s, the building continued to serve as a hotel for another decade and was later converted to apartments. The building retains integrity and meets the registration requirements set forth in the multiple property documentation form entitled "Historic and Architectural Resources of the City of Cuba, Missouri, 1821-1963" and the associated property types "III-A Commercial Buildings" in addition to subtype "III-C: Roadside Architecture." The building spans two historic contexts including "Railroads and Industry, 1866-1926" and "Route 66 and the Great Depression, 1926-1945."

Background – Founding of Cuba, Missouri and the Coming of the Railroad

Crawford County, Missouri was organized in 1829 and by 1837, the area that later became Cuba was first settled. Two decades later when the town was being surveyed for a proposed railroad line two local families consisting of Robert P. and Mary E. Jamison and C. Wesley and Mary Smith filed an official plat for "Cuba City."¹ As plated, Cuba was comprised of thirty-two blocks divided in half by the proposed railroad line; North Main and South Main fronted the tracks. Street names were different running north and south and changed identity once crossing the tracks. As designed, the new town was a typical railroad town with business facing the tracks and residential was separated. This would change again with the advent of the automobile.

By 1859, the Southwest Branch of the Pacific Railroad was completed through Cuba and by 1861 it had extended to Rolla; the railroad also divided Cuba into two unofficial

¹ Steven E. and Mary Aue Mitchell. "Cuba, Crawford County, Architectural/Historical Survey." February 2007, HPF grant# 29-06-21528-612, page 4. The plat was not recorded until June 3, 1892.

National Register of Historic Places
Continuation Sheet

Section number 8 Page 5

Hotel Cuba
Name of Property
Crawford County, Missouri
County and State
Name of multiple listing (if applicable): Historical and Architectural Resources of the City of Cuba, Missouri, 1821-1963

communities, North Cuba and South Cuba.² The majority of businesses located to the north of the tracks but development of the town was slow. On May 12, 1877, Cuba was incorporated as a village and within four years its population numbered almost 400.³ Besides the growing population, there was also a rising trend of individuals riding the railroad to points beyond Cuba; final destinations often were interrupted by a stay in Cuba to catch a second train. To meet the need, a series of hotels began to spring up adjacent the railroad.

Elaboration - Hotels as Successful Ventures

Hotels in Cuba first appeared on the local scene as a result of the railroad and increased visitors; one such, the McClay House stood across from the depot and was two-stories in height with fifteen rooms.⁴ Other hotels sprang up in 1872 with the American Hotel (north side of South Smith), circa 1875 with the first Cuba Hotel (North Main between Meramec and Wall), in 1897 with the Hotel Grand near the tracks, in 1906 with the Hotel Dowley, in 1922 with the Hotel Central (West Washington), and several others through 1938.

Between 1915 and 1922, six new hotels were built or renovated in Cuba and a number of restaurants, shops and bars sprang up to exploit the influx of visitors.⁵ The subject building began its life first as the Palace Hotel in 1915 and was constructed to serve railroad travelers (Figure 2). Replacing earlier structures on the city block (Figure 3), the new hotel was larger and more modern (Figure 4) and its future seemed bright. However, its business boomed for just a decade due to decreased railroad passenger trains. Also, due in part to poor roads, the hotel boom in Cuba was short lived. The Palace Hotel and several other local hotels began to close as a result.⁶

Under the Federal Highway Interstate Highway System Act in 1926, State Highway 14, which ran through Cuba along Washington Avenue (the north boundary of the subject hotel), was designated Route 66. Although Route 66 did not immediately usurp the railroad's role as transporter of goods and passengers, the effect of the new highway was dramatic and eventually decisive.⁷ It was this change which prompted the

² Ibid. page 6.

³ "Cuba." *Gazetteer and Business Directory of the New Southwest*. (St. Louis: United States Directory Publishing Company, 1881).

⁴ Steven E. and Mary Aue Mitchell. page 13.

⁵ Ibid. pages 13 and 19.

⁶ David Taylor. "Historical and Architectural Resources of the City of Cuba, Missouri, 1821-1963." Multiple Property Documentation Form. 2012, Section E, Pages 13-14.

⁷ Steven E. and Mary Aue Mitchell, pages 19-20.

National Register of Historic Places
Continuation Sheet

Section number 8 Page 6

Hotel Cuba
Name of Property
Crawford County, Missouri
County and State
Name of multiple listing (if applicable): Historical and Architectural Resources of the City of Cuba, Missouri, 1821-1963

owners of the hotel to add an additional entrance facing Washington—now Route 66. Other Cuba hotels did not follow suite right away and the Palace Hotel was able to reinvent itself as the Hotel Cuba in 1926 (Figure 5).

Figure 2: Original City Plat. General site of Hotel Cuba is circled to the right. Source: Cuba Historical Society.

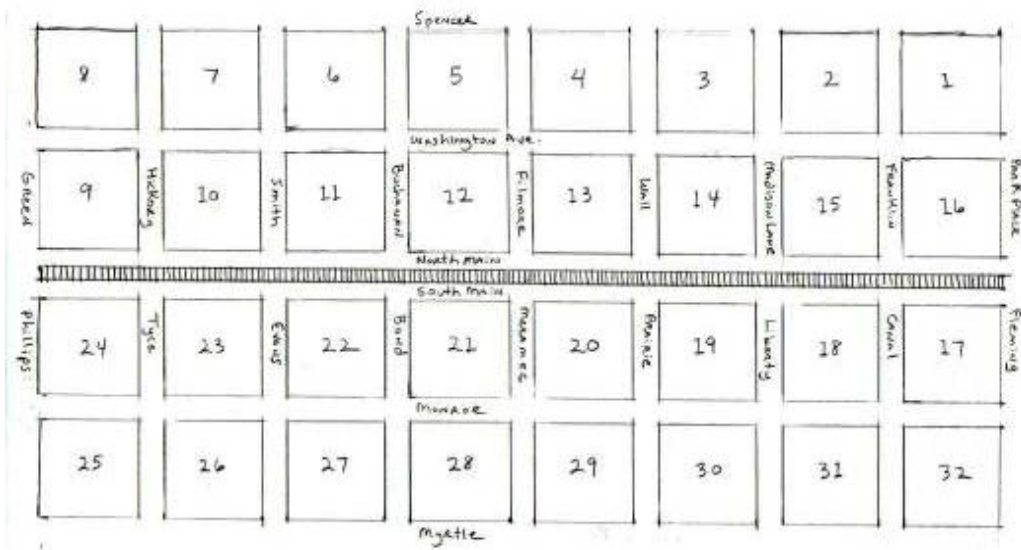
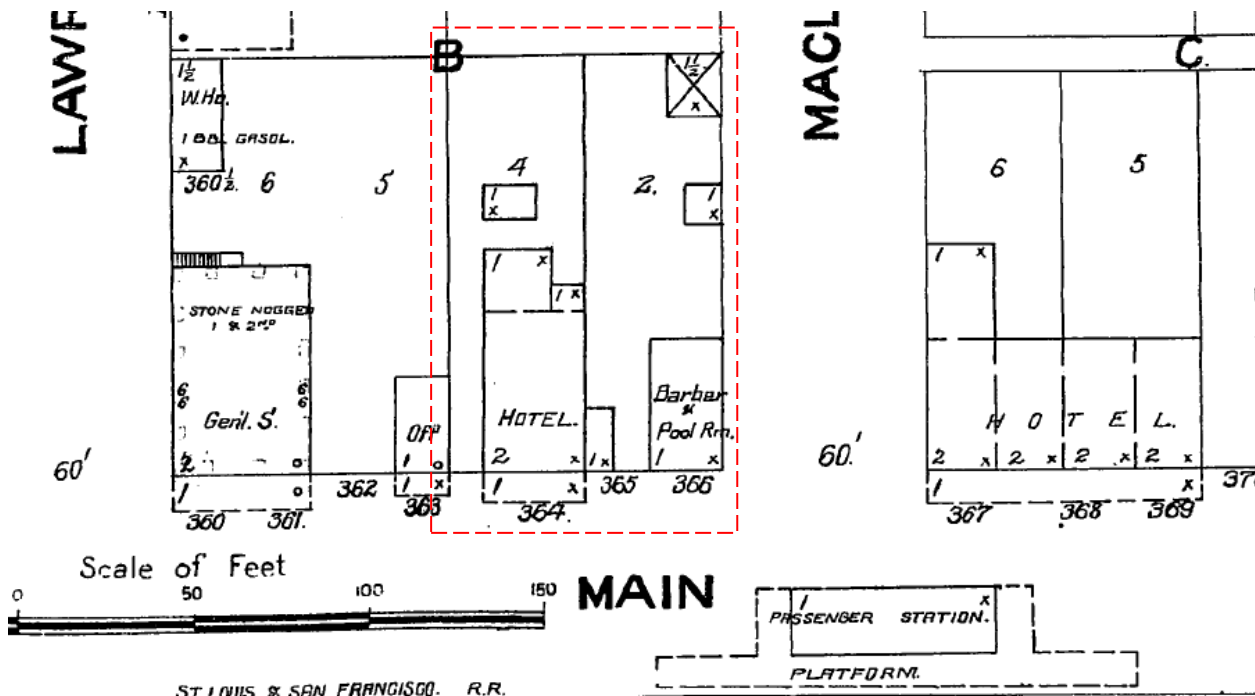

Figure 3: Sanborn Fire Insurance Map, 1914. Shows earlier buildings on site demolished.



National Register of Historic Places
 Continuation Sheet

Section number 8 Page 7

Hotel Cuba
Name of Property
Crawford County, Missouri
County and State
Name of multiple listing (if applicable): Historical and Architectural Resources of the City of Cuba, Missouri, 1821-1963

Figure 4: Sanborn Fire Insurance Map, 1924. Site of nominated building as it appeared prior to 1926.

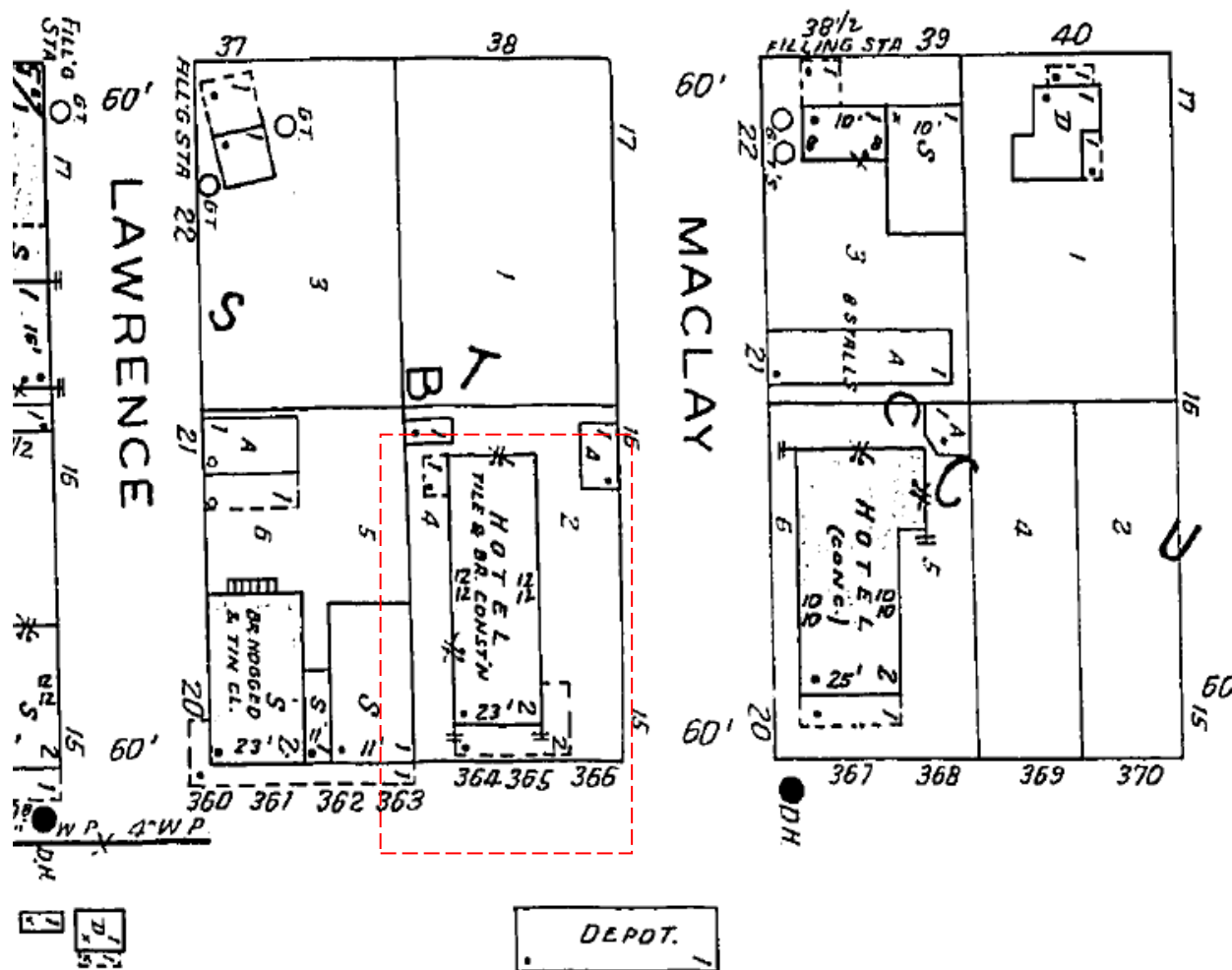

Cuba Survey

The "Cuba, Crawford County, Architectural/Historical Survey" conducted by Steven E. and Mary Aue Mitchell in February of 2007 explains that during the period "Railroads and Industry, 1866-1926" hotels were among Cuba's earliest and most enduring businesses, their success first dependent on Cuba's location on the railroad and later on a major national highway, Route 66.⁸ They further explain that within the Commercial Buildings Property Type that Cuba's earliest associated commercial buildings flanked the railroad. This would change however when State Highway 14

⁸ Ibid. page 13.

National Register of Historic Places
Continuation Sheet

Section number 8 Page 8

Hotel Cuba
Name of Property
Crawford County, Missouri
County and State
Name of multiple listing (if applicable): Historical and Architectural Resources of the City of Cuba, Missouri, 1821-1963

which ran through Cuba was designated Route 66; this change marked the beginning of the shift of businesses from the Main Street and railroad area to the suddenly significant new corridor.⁹ As a response, the authors conclude that the nominated building was “probably the most obvious example of the commercial response to the new highway.”¹⁰ A look at the physical design of the hotel clearly illustrates the dual entrance aspect with an intentional focus on the Route 66 elevation. The nominated building thus represents two contexts. The Route 66 survey prepared by Becky Snider and Deb Sheals in 2003 verifies that the Hotel Cuba was in fact representative of the change in attention from railroad to automobile travelers.¹¹

Figure 5: Postcard of the Hotel Cuba, Cuba, Missouri, ca. 1940.



⁹ Ibid. page 37.

¹⁰ Ibid.

¹¹ Becky L. Snider, Ph.D. and Debbie Sheals. “ROUTE 66 IN MISSOURI SURVEY AND NATIONAL REGISTER PROJECT.” PROJECT NO. S7215MSFACG, 2003.

National Register of Historic Places
Continuation Sheet

Section number 8 Page 9

Hotel Cuba
Name of Property
Crawford County, Missouri
County and State
Name of multiple listing (if applicable): Historical and Architectural Resources of the City of Cuba, Missouri, 1821-1963

The MPDF and Associated Historic Context

Based upon the historic timelines as illustrated in the MPDF, the Hotel Cuba was constructed during the period "Railroads and Industry, 1866-1926." Built in 1915, it served a major role in providing boarding for travelers coming via rail to and through Cuba. Erected on Main Street across the railroad tracks and adjacent the train depot, the nominated building known originally as the Palace Hotel contributed to the commercial and social environment of Cuba during this phase in local history which centered around the railroad. Competition to attract travelers resulted in many local hotels losing business once the railroad began to carry fewer passengers; new competition with the automobile was a challenge that was immediately addressed by the Hotel Cuba. Seeing the new transportation possibility as an asset, the owners of the hotel answered the call by constructing a new addition in association with Route 66.

Additional association with the context "Route 66 and the Great Depression, 1926-1945" was achieved when the owner's added this second entrance at Route 66.¹² Creating a new entrance lobby facing the highway, the owners also added new signage and a parking lot for automobiles. The Hotel Cuba as it was renamed, served a dual purpose supporting both modes of transportation. The building soon became one of the official stops along Route 66 (Figure 5) and business boomed for the next few decades.

The property is a good representative example of the "Property Type III-A: Commercial Buildings" as well as having a contribution to type "III-C: Roadside Architecture" as described in the MPDF.¹³ Demonstrative of the property types, this building was erected as a railroad hotel in 1915 and then later adapted to automobile travelers in conjunction with Route 66 in 1926. The building also represents the only extant hotel in Cuba which illustrates both connections.¹⁴ The role of the Hotel Cuba within the growth of the social life of Cuba and its direct connection to the commercial history of the town are clearly representative in the building which stands today. In meeting the registration requirements as set forth in the MPDF, the nominated building is a representative example of the property type as it was designed and constructed specifically to function as a commercial building in downtown Cuba; additionally it was an important component of the business growth of Cuba as it catered to railroad travelers coming to and through Cuba and stopping to shop in its downtown stores.¹⁵

¹² Ibid.

¹³ David Taylor. Section F, Page 7.

¹⁴ Ibid, Section E, page 22.

¹⁵ David Taylor. Section F, Page 6.

National Register of Historic Places
Continuation Sheet

Section number 8 Page 10

Hotel Cuba
Name of Property
Crawford County, Missouri
County and State
Name of multiple listing (if applicable): Historical and Architectural Resources of the City of Cuba, Missouri, 1821-1963

Definitely not the work of a formally-trained architect, this two-story structure has the indicative flat roof with parapet that many other local commercial buildings bear.

The Hotel Cuba is further significant under Criterion A in commerce because it is a good example of a specific property type (hotel) and it played a direct role in the story of the commercial and industrial development in Cuba. The building clearly reflects the economic forces that contributed to the development of Cuba and has additional significance as it was adapted to address the historic transportation artery Route 66.¹⁶

The building retains integrity of location, design, setting, workmanship, feeling and association. Despite replacement windows and some modifications within interior units of the building, original materials such as the brick are intact. From visual inspection, the only exterior modifications appear to be the installation of new replacement windows and some boarded bays. The interior has been slightly modified to house apartments but the long circulation corridors separating the east and west unit sides remain intact. The MPDF explains that changes to the interior are not typically significant due to the nature of the building.

To be listed individually in the National Register in accordance with the MPDF, the Hotel Cuba represents the characteristics and qualities of commercial growth in respect to both aforementioned historic contexts. The building further retains its original and early design and form, massing, and rhythm (despite infilled window openings), the original door and window fenestration, original exterior materials, and lastly has an obvious physical character representative of its time. The building clearly reflects its period of significance from 1915 to 1926 in that it retains both the original Railroad façade and the later Route 66 facade. Perhaps more importantly, the building exterior has not changed since adapted to Route 66 traffic (despite infilled window openings); no new additions have been constructed. Essential to the development of the building in context of both the Railroad and Route 66, it retains both entrances reflective of the building's evolution.

Conclusion

National Register of Historic Places
Continuation Sheet

Section number 8 Page 11

Hotel Cuba

Name of Property

Crawford County, Missouri

County and State

Name of multiple listing (if applicable): Historical and Architectural
Resources of the City of Cuba, Missouri, 1821-1963

The building retains integrity and meets the registration requirements set forth in the multiple property documentation form entitled "Historic and Architectural Resources of the City of Cuba, Missouri, 1821-1963" and the associated property types "III-A Commercial Buildings" in addition to subtype "III-C: Roadside Architecture" as an intact example of a commercial hotel which succeeded in Cuba in part to its ability to adapt to changing modes of transportation as the city grew from a railroad town into one accessed by automobiles. The building thus also spans two historic contexts including "Railroads and Industry, 1866-1926" and "Route 66 and the Great Depression, 1926-1945" as described in the MPDF and has a direct association with the commercial growth of Cuba during its historic development.

¹⁶ Becky L. Snider, Ph.D. and Debbie Sheals.

National Register of Historic Places
Continuation Sheet

Section number 9 Page 12

Hotel Cuba

Name of Property

Crawford County, Missouri

County and State

Name of multiple listing (if applicable): Historical and Architectural
Resources of the City of Cuba, Missouri, 1821-1963

Bibliography

Boyd, Gregory A. "Family Maps of Crawford County, Missouri." (Arphax Publishing Company, 2006).

Breuer, James Ira. "Crawford County and Cuba, Missouri, with a Supplement, Oak Grove School." (Cape Girardeau, MO: Ramfre Press, 1972).

_____. "History of Cuba's Founding Fathers," Crawford Mirror, January 3, 1974, in Breuer Scrapbooks: Newspapers, 1976—1982, Misc. Articles, located in Crawford County Historical Society, Cuba, Missouri.

Carley, Rachel. "Visual Dictionary of American Domestic Architecture." (New York: Henry Holt and Company, 1997).

City of Cuba Government. Various public records, property data.

Collier, James E. "Geographic Regions of Missouri." In *Annals of the Association of American Geographers*. Volume 45 (December 1955).

Crawford County, Missouri Assessor. Various public records, property data.

"Cuba Centennial: 100 Years of Growth & Progress- 1857-1957." (Cuba, MO: 1957).

Cuba Sesquicentennial Book Committee. "Celebrating 150 Years: A History of Cuba, Missouri- 1857-2007." (Cuba, MO: 2008).

"Gazetteer and Business Directory of the New Southwest." (St. Louis, MO: United States Directory Publishing Company, 1881).

Harvey, Thomas. "Railroad Towns: Urban Form of the Prairie." In *Landscape*. Volume 27, 1983.

Hentzel, David R. "Apples and Shoes: The Economics of a Small Town." (Rolla, MO: The author, 1988).

History of Franklin, Jefferson, Washington, Crawford and Gasconade Counties, Missouri. Chicago: Goodspeed Publishing Company, 1888.

National Register of Historic Places
Continuation Sheet

Section number 9 Page 13

Hotel Cuba
Name of Property
Crawford County, Missouri
County and State
Name of multiple listing (if applicable): Historical and Architectural Resources of the City of Cuba, Missouri, 1821-1963

Kersten, Earl W., Jr. "Changing Economy and Landscape in A Missouri Ozarks Area." In *Annals of the Association of American Geographers*. Volume 48 (1958).

Meramec Regional Planning Commission. "History of Crawford County—Historic Preservation Program, Phase IV: Historic Inventory of Crawford County." Project Number 29-83-7517. November 1, 1982—September 30, 1984.

Mitchell, Steven E. and Mary Aue. "Cuba, Crawford County, Architectural/Historical Survey." February 2007, HPF grant# 29-06-21528-612.

Munro, A. Manson. "History of Cuba." Prepared for the Centennial, 1957. n.d.

Sanborn Map Company. "Sanborn Fire Insurance Map of Cuba, Missouri." (New York: Sanborn Map Company, 1924 and 1933).

Snider, Becky L., and Debbie Sheals. "Route 66 in Missouri Survey and National Register Project, Project No. S7215MSFACG: Survey Report." January 14, 2003.
<http://www.cr.nps.gov/rt66/HistSig/MissouriContext.htm>. Accessed December 20, 2013.

Taylor, David. "Historical and Architectural Resources of the City of Cuba, Missouri, 1821-1963." Multiple Property Documentation Form. 2012.

National Register of Historic Places
Continuation Sheet

Section number 10 Page 14

Hotel Cuba

Name of Property
Crawford County, Missouri

County and State
Name of multiple listing (if applicable): Historical and Architectural Resources of the City of Cuba, Missouri, 1821-1963

Verbal Boundary Description

The Hotel Cuba at 600 East Main Street in Cuba, Crawford County, Missouri, is associated with tax code 21NR-S2-R1-AN and is identified as parcel number 06-9.0-31-1-05-002.000. A dotted outline on the accompanying map entitled "Hotel Cuba Boundary Map" indicates the boundary of the nominated property.

Boundary Justification

The nominated property includes the building and lot which is historically associated with the property.

"Hotel Cuba Boundary Map"



National Register of Historic Places
 Continuation Sheet

Section number 10 Page 15

Hotel Cuba
Name of Property
Crawford County, Missouri
County and State
Name of multiple listing (if applicable): Historical and Architectural Resources of the City of Cuba, Missouri, 1821-1963

Photo Key and First Floor Plan

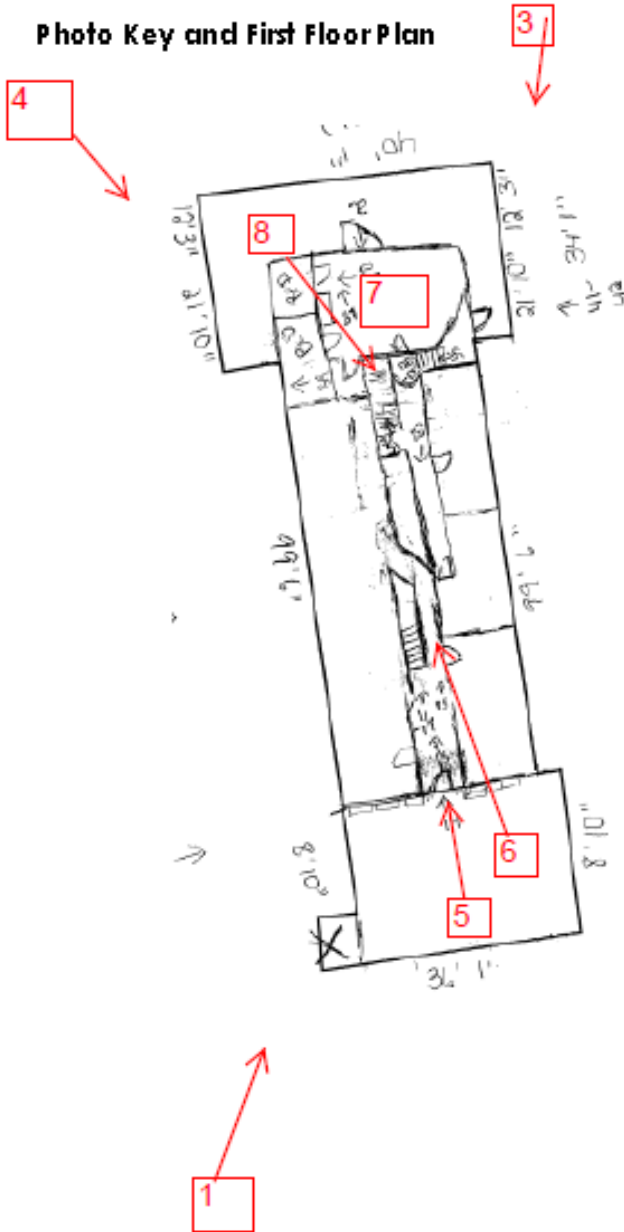

North

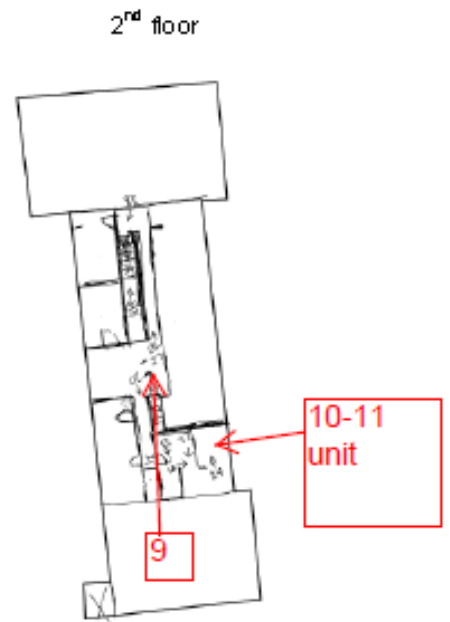





WG2 L6J

309



KINGDOM

White sign leaning against the porch steps.



WARNING
Security 
Cameras In Use





106



believe

